

SWISSDIS



Swissdis AG
Grasweg 7
CH-4911 Schwarzhäusern

Tel.: +41 62 919 44 00
Fax: +41 62 919 44 01
info@swissdis.ch
www.swissdis.ch



SPECIFICATIONS

SD1022-V00

Swissdis 108144

LCD Module Graphic 240x64 Dots
With LED Backlight white

Viewing direction
6 o'clock

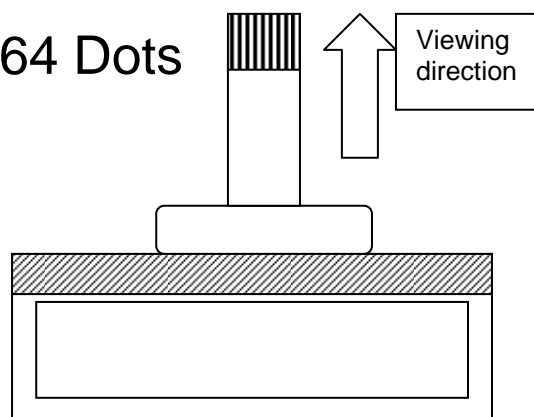

Version November 2012

REVISION RECORD (MODEL NO.: SD1022-V00)

Revision	Revision Date	Page	Contents
A	2012/06/29		Initial Release and Issue Full Specification.
B	2012/09/18		Improve the backlight.
C	2012/11/21		Improve the backlight.



CONTENTS

※ CONTENTS

1. FEATURES
2. MECHANICAL SPECIFICATIONS
3. ELECTRICAL SPECIFICATIONS
4. POWER SUPPLY
5. ELECTRO-OPTICAL CHARACTERISTICS
6. INTERFACE PIN FUNCTION
7. COMMAND LIST
8. TIMING CHARACTERISTICS
9. QUALITY SPECIFICATION
10. RELIABILITY
11. HANDLING PRECAUTION
12. OUTLINE DIMENSION

- ※ ANNEX : 1. SAMPLES OUTGOING INSPECTION REPORT
2. REVISION RECORD

MODEL	SD1022-V00	1/17	PRODUCT SPECIFICATIONS	REV: C
-------	------------	------	------------------------	--------

1. FEATURES

The features of LCD are as follows

- * Display mode : FSTN, Positive, Transflective
- * Color : Display dot : Black
Background: White
- * Display Format : 240 × 64 Dots graphic
- * IC : SITRONIX ST7565P-G *2 Chip
- * Interface Input Data : Series MPU
- * Driving Method : 1/65 Duty, 1/7 Bias
- * Viewing Direction : 6 O'clock
- * Backlight : LED(White)
- * LCM technological conditions: **RoHS**

2. MECHANICAL SPECIFICATIONS

Item	Specification	Unit
Module Size	109.6 (W) X 134.82(H) X 5.5(T)	mm
Viewing Area	102.4(W) X 30.22(H)	mm
Effective Display Area	98.38(W) X 26.22(H)	mm
Number of Dots	240 X 64Dots	-
Dot Size	0.39(W) X 0.39(H)	mm
Dot Pitch	0.41(W) X 0.41(H)	mm

3. ELECTRICAL SPECIFICATIONS

3-1. Absolute Maximum Ratings (V_{ss}=0V)

Item	Symbol	Standard Value			Unit
		Min.	Typ.	Max.	
Supply Voltage For Logic	V _{DD}	0.3	-	3.6	V
Supply Voltage For LCD Drive	V _{0 . Vout}	0.3	-	14.5	V
Operating Temp.	T _{OP}	-20	-	+70	°C
Storage Temp.	T _{ST}	-30	-	+80	°C
Static Electricity	Be sure that you are ground when handing LCM				

MODEL	SD1022-V00	2/17	PRODUCT SPECIFICATIONS	REV: C
-------	------------	------	------------------------	--------

3. ELECTRICAL SPECIFICATIONS (Continued)

3-2-1. Electrical Characteristics

Item	Symbol	Test Condition	Min.	Typ.	Max.	Unit
Supply Voltage For Logic	$V_{DD} - V_{SS}$	$T_a=25^{\circ}\text{C}$	2.7	3.0	3.3	V
Supply Voltage For LCD	$V_{DD} - V_{SS}$	$T_a=25^{\circ}\text{C}$	7.8	8.0	8.3	V
Input Voltage	"H" Level	$T_a=25^{\circ}\text{C}$	$0.8V_{DD}$	-	V_{DD}	V
	"L" Level		V_{SS}	-	$0.2V_{DD}$	V
Output Voltage	"H" Level	$I_{OUT} = -0.5\text{mA}$	$0.8V_{DD}$	-	V_{DD}	V
	"L" Level	$I_{OL} = 0.5\text{mA}$	V_{SS}	-	$0.2V_{DD}$	V
Current Consumption	I_{DD}	-	-	1.5	3.0	mA

NOTE: 1) Duty ratio=1/65, Bias=1/7

2) Measured in Dots ON-state

3-3. Backlight

3-3-1. Absolute Maximum Ratings at $T_a=25^{\circ}\text{C}$

Item	Symbol	Rating	Unit
Absolute maximum forward current	I_f	200	mA
Reverse Voltage	V_r	4	V
Power Dissipation	P_d	840	mW
Storage Temperature Range	T_{stg}	-30~+80	$^{\circ}\text{C}$
Hand Soldering Temperature		/	-

3-3-2. Electronic Optical Characteristics ($I_f=120\text{mA}$)

Item	Symbol	Min.	Typ.	Max	Unit
Forward Voltage	V_F	3.8	4.0	4.2	V
Luminous Intensity	I_v	500	670	-	cd/m^2
Uniformity	U	70	-	-	%
Colour Coordinate	X	0.28	0.31	0.34	
	Y	0.28	0.31	0.34	nm

* The brightness is measured without LCD panel

MODEL	SD1022-V00	3/17	PRODUCT SPECIFICATIONS	REV: C
-------	------------	------	------------------------	--------

4. POWER SUPPLY and BLOCK DIAGRAM

4-1 Power supply

(1) When the voltage regulator internal resistor is used.

(Example where $V_{DD2} = V_{DD}$, with 4x step-up)

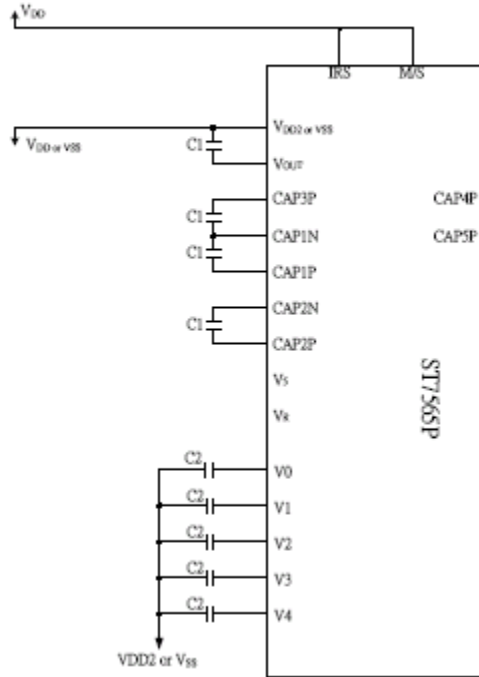

Note: 1. C1: 1.0 to 4.7 μ F

2. C2: 0.1 to 4.7 μ F

4-2 Block diagram

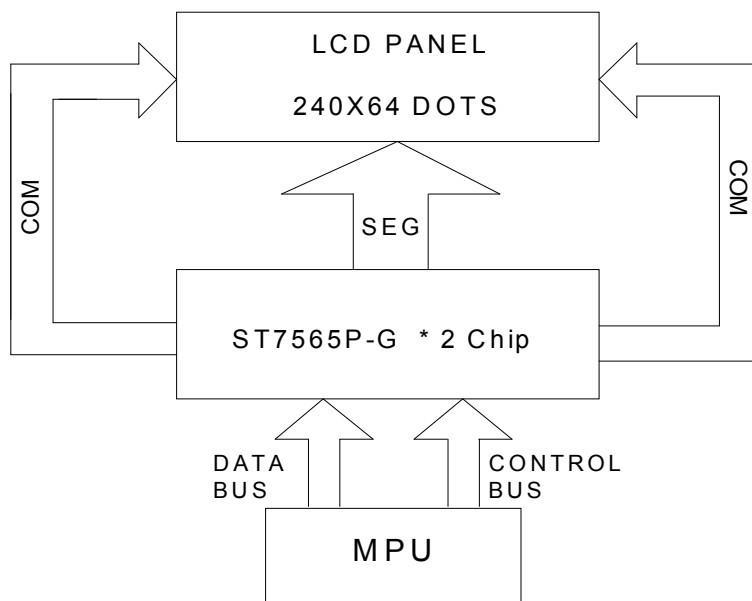

5. ELECTRO – OPTICAL CHARACTERISTICS

Item	Symbol	Temp.	Min.	Typ.	Max.	Unit	Conditions	Note
Viewing Angle $Cr \geq 2$	$\Phi = 0^\circ$	25°C	--	30	--	Deg.	-	1,2
	$\Phi = 180^\circ$		--	28	--			
	$\Phi = 90^\circ$		--	30	--			
	$\Phi = 270^\circ$		--	26	--			
Viewing Direction		6 O'clock						
Contrast Ratio	Cr	25°C	2.0	3.06	3.18	-	$\Theta = 0^\circ$ $\Phi = 0^\circ$	3
Response Time(rise)	Tr	25°C	-	208	350	ms	$\Theta = 0^\circ$ $\Phi = 0^\circ$	4
		0°C	-	950	1150			
Response Time(fall)	Tf	25°C	-	268	350	ms	$\Theta = 0^\circ$ $\Phi = 0^\circ$	4
		0°C	-	950	1150			

Note1. Definition of Angle $\Theta Y1$ & $\Theta Y2$

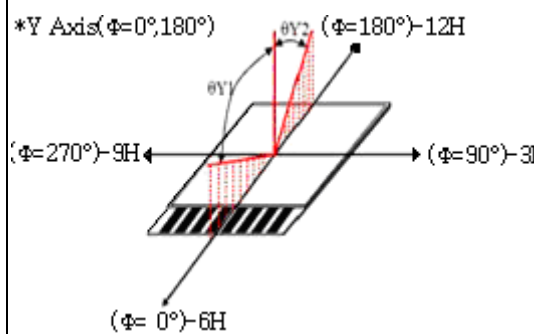

Note2. Definition of Viewing Angle $\Theta X1$ & $\Theta X2$

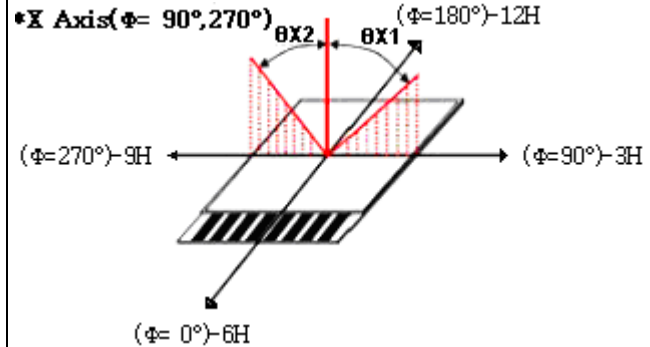

Note3. Definition of Contrast Cr

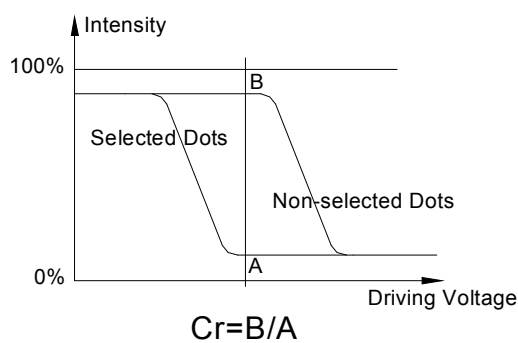

Note4. Definition of Optical Response

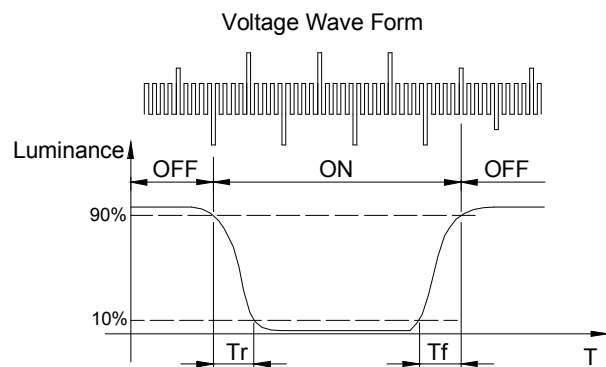

MODEL

SD1022-V00

5/17

PRODUCT SPECIFICATIONS

REV: C

6. INTERFACE PIN FUNCTION

Pin NO.	Symbol	I / O	Functions
1	/RES	I	When /RES is set to "L", the settings are initialized.
2	/CSA	I	This is the chip select signal. When /CSA = "L" master(A) chip select becomes active.
3	/CSB	I	This is the chip select signal. When /CSB = "L" Slave(B) chip select becomes active.
4	A0	I	This is connected to the least significant bit of the normal MPU address bus, and it determines whether the data bits are data or a command.
5	SCL	I	Serial clock input.
6	SI	I	Serial data input.
7	V _{DD}	Power Supply	Power Supply.
8	V _{SS}	Power Supply	Ground.
9	V _{OUT}	O	DC/DC voltage converter. Connect a capacitor between this terminal and V _{SS} or V _{DD} .
10	CAP3P	O	DC/DC Voltage converter. Connect a capacitor between this terminal and the CAP1N terminal.
11	CAP1N	O	DC/DC Voltage converter. Connect a capacitor between this terminal and the CAP1P terminal.
12	CAP1P	O	DC/DC Voltage converter. Connect a capacitor between this terminal and the CAP1N terminal.
13	CAP2P	O	DC/DC Voltage converter. Connect a capacitor between this terminal and the CAP2N terminal.
14	CAP2N	O	DC/DC Voltage converter. Connect a capacitor between this terminal and the CAP2P terminal.
15~19	V ₄ ~V ₀	Power Supply	This is a multi-level power supply for the liquid crystal drive. Voltage levels are determined based on V _{SS} , and must maintain the relative magnitudes shown below. V ₀ >V ₁ >V ₂ >V ₃ >V ₄ >V _{SS} .
20	VR	I	Output voltage regulator terminal. Provides the voltage between V _{SS} and V ₀ through a resistive voltage divider.
21	IRS	I	This terminal selects the resistors for the V ₀ voltage level adjustment.
22	NC	/	No Connect.

MODEL

SD1022-V00

6/17

PRODUCT SPECIFICATIONS

REV: C

7. COMMAND LIST

Command	Command Code									Function			
	A0	/RD	/WR	D7	D6	D5	D4	D3	D2		D1	D0	
(1) Display ON/OFF	0	1	0	1	0	1	0	1	1	1	0	1	LCD display ON/OFF 0: OFF, 1: ON
(2) Display start line set	0	1	0	0	1	Display start address						1	Sets the display RAM display start line address
(3) Page address set	0	1	0	1	0	1	1	Page address				0	Sets the display RAM page address
(4) Column address set upper bit	0	1	0	0	0	0	1	Most significant column address				0	Sets the most significant 4 bits of the display RAM column address.
Column address set lower bit	0	1	0	0	0	0	0	Least significant column address				0	Sets the least significant 4 bits of the display RAM column address.
(5) Status read	0	0	1	Status				0	0	0	0	0	Reads the status data
(6) Display data write	1	1	0	Write data								0	Writes to the display RAM
(7) Display data read	1	0	1	Read data								0	Reads from the display RAM
(8) ADC select	0	1	0	1	0	1	0	0	0	0	0	0	Sets the display RAM address SEG output correspondence 0: normal, 1: reverse
(9) Display normal/reverse	0	1	0	1	0	1	0	0	1	1	0	1	Sets the LCD display normal/reverse 0: normal, 1: reverse
(10) Display all points ON/OFF	0	1	0	1	0	1	0	0	1	0	0	1	Display all points 0: normal display 1: all points ON
(11) LCD bias set	0	1	0	1	0	1	0	0	0	1	0	1	Sets the LCD drive voltage bias ratio 0: 1/9 bias, 1: 1/7 bias (ST7565P)
(12) Read/modify/write	0	1	0	1	1	1	0	0	0	0	0	0	Column address increment At write: +1 At read: 0
(13) End	0	1	0	1	1	1	0	1	1	1	0	0	Clear read/modify/write
(14) Reset	0	1	0	1	1	1	0	0	0	1	0	0	Internal reset
(15) Common output mode select	0	1	0	1	1	0	0	0	1	*	*	*	Select COM output scan direction 0: normal direction 1: reverse direction
(16) Power control set	0	1	0	0	0	1	0	1	Operating mode			0	Select internal power supply operating mode
(17) V ₀ voltage regulator internal resistor ratio set	0	1	0	0	0	1	0	0	Resistor ratio			0	Select internal resistor ratio(R _b /R _a) mode
(18) Electronic volume mode set	0	1	0	1	0	0	0	0	0	0	0	1	Set the V ₀ output voltage electronic volume register
Electronic volume register set				0	0	Electronic volume value							
(19) Static indicator ON/OFF	0	1	0	1	0	1	0	1	1	0	0	1	0: OFF, 1: ON
Static indicator register set				0	0	0	0	0	0	0	0	0	0
(20) Booster ratio set	0	1	0	1	1	1	1	1	0	0	0	0	select booster ratio 00: 2x,3x,4x 01: 5x 11: 6x
(21) Power saver													Display OFF and display all points ON compound command
(22) NOP	0	1	0	1	1	1	0	0	0	1	1	1	Command for non-operation
(23) Test	0	1	0	1	1	1	1	*	*	*	*	*	Command for IC test. Do not use this command

MODEL

SD1022-V00

7/17

PRODUCT SPECIFICATIONS

REV: C

8.TIMING CHARACTERISTICS (Continued)

8-3.The Serial Interface

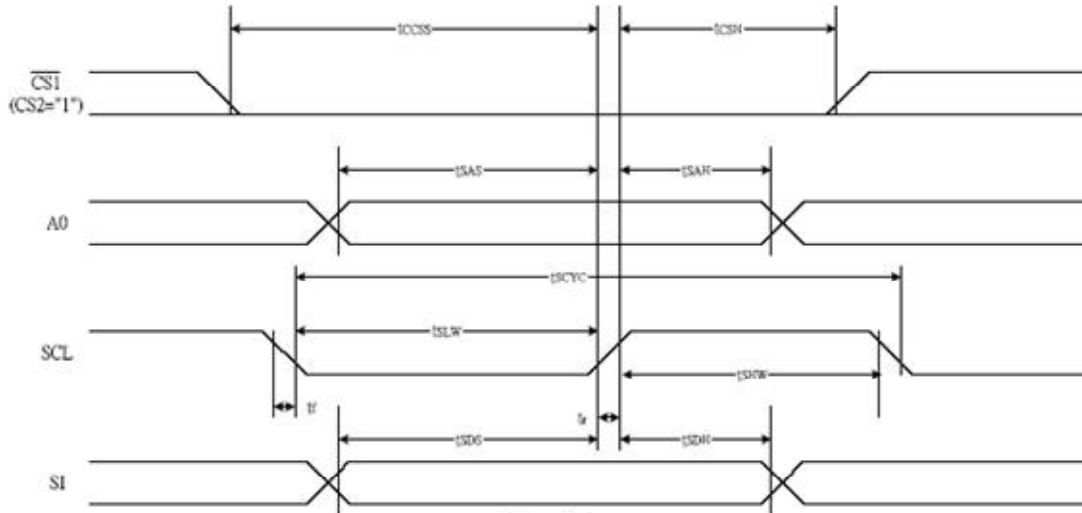

Figure 39

Table 30

(V_{DD} = 3.3V, T_a = 25°C)

Item	Signal	Symbol	Condition	Rating		Units
				Min.	Max.	
Serial Clock Period		T _{scyc}		50	—	ns
SCL "H" pulse width	SCL	T _{shw}		25	—	
SCL "L" pulse width		T _{slw}		25	—	
Address setup time	A0	T _{sas}		20	—	
Address hold time		T _{сах}		10	—	
Data setup time	SI	T _{sd}		20	—	
Data hold time		T _{sdh}		10	—	
CS-SCL time	CS	T _{css}		20	—	
CS-SCL time		T _{csh}		40	—	

*1 The input signal rise and fall time (tr, tf) are specified at 15 ns or less.

*2 All timing is specified using 20% and 80% of V_{DD} as the standard.

8-4. Reset Timing

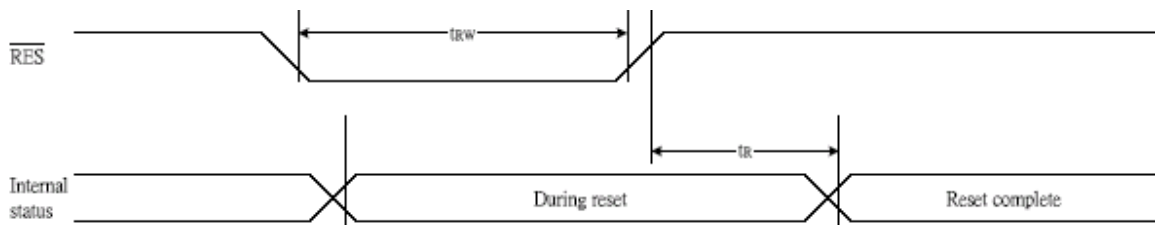

(V_{DD} = 3.3V, T_a = -40 to 85°C)

Item	Signal	Symbol	Condition	Rating			Units
				Min.	Typ.	Max.	
Reset time		tr		—	—	1.0	us
Reset "L" pulse width	/RES	trw		1.0	—	—	us

9. QUALITY SPECIFICATION

9 - 1. LCM Appearance and Electric inspection Condition

1. Inspection will be done by placing LCM 30cm away from inspector's eyeballs under normal illumination.

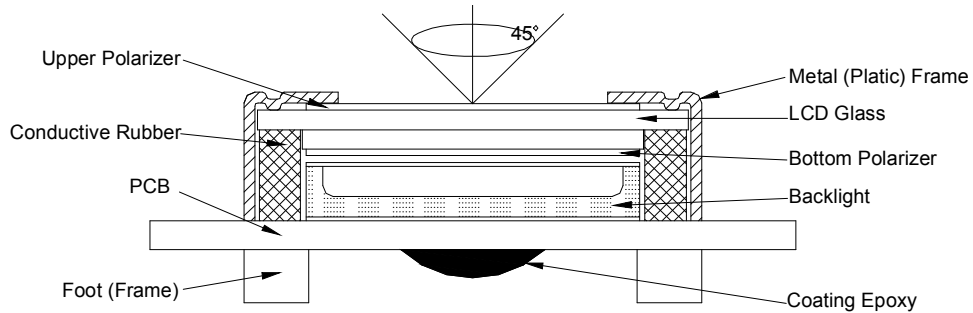

2. View Angle: with in 45° around perpendicular line.

9 - 2. Definition

1. COB

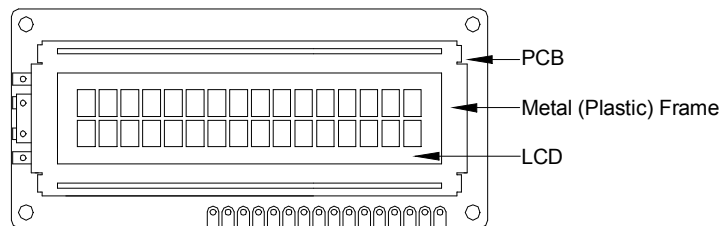

2. Heat Seal

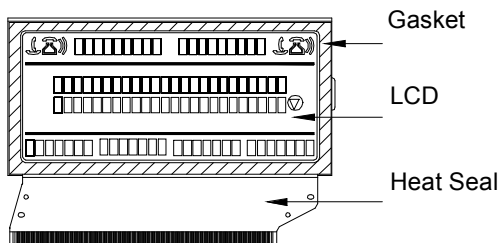

3. TAB and COG

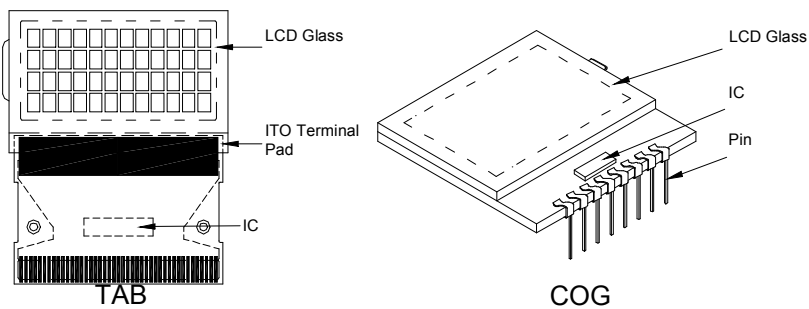

MODEL

SD1022-V00

9/17

PRODUCT SPECIFICATIONS

REV: C

9. QUALITY SPECIFICATION (Continued)

9-3. Sampling Plan and Acceptance

1. Sampling Plan

MIL - STD - 105E (||) ordinary single inspection is used.

2. Acceptance

Major defect: AQL = 0.25

Minor defect: AQL = 0.65

9-4. Criteria

1. COB

Defect	Inspection Item	Inspection Standards	
Major	PCB copper flakes peeling off	Any copper flake in viewing Area should be greater than 1.0mm ²	Reject
Major	Height of coating epoxy	Exceed the dimension of drawing	Reject
Major	Void or hole of coating epoxy	Expose bonding wire or IC	Reject
Major	PCB cutting defect	Exceed the dimension of drawing	Reject

2. SMT

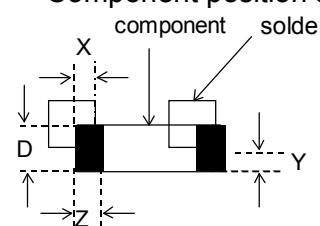
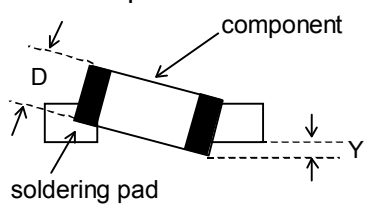
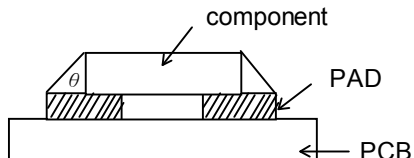
Defect	Inspection Item	Inspection Standards	
Minor	Component marking not readable		Reject
Minor	Component height	Exceed the dimension Of drawing	Reject
Major	Component solder defect (missing , extra, wrong component or wrong orientation)		Reject
Minor	Component position shift 	$X < 3/4Z$ $Y > 1/3D$	Reject Reject
Minor	Component tilt 	$Y > 1/3D$	Reject
Minor	Insufficient solder 	$\theta \leq 20^\circ$	Reject

MODEL

SD1022-V00

10/17

PRODUCT SPECIFICATIONS

REV: C

9. QUALITY SECIFICATION (Continued)

9-4. Criteria (Continued)

3. Metal (Plastic) Frame

Defect	Inspection Item	Inspection Standards		
Major	Crack / breakage	Anywhere		Reject
Minor	Frame Scratch	W	L	Acceptable of Scratch
		w<0.1mm	Any	Ignore
		0.1≤w<0.2mm	L≤5.0mm	2
		0.2≤w<0.3mm	L≤3.0mm	1
		w≥0.3mm	Any	0
		Note : 1. Above criteria applicable to scratch lines with distance greater than 5mm. 2. Scratch on the back side of frame (not visible) can be ignored .		
Minor	Frame Dent , Prick $\Phi = \frac{L + W}{2}$			Acceptable of Dents / Pricks
		$\Phi \leq 1.0\text{mm}$		2
		$1.0 < \Phi \leq 1.5\text{mm}$		1
		$1.5\text{mm} < \Phi$		0
		Note : 1. Above criteria applicable to any two dents / pricks with distance greater than 5mm 2. Dent / prick on the back side of frame (not visible) can be ignored		
Minor	Frame Deformation	Exceed the dimension of drawing		
Minor	Metal Frame Oxidation	Any rust		

4. Flexible Film Connector (FFC)

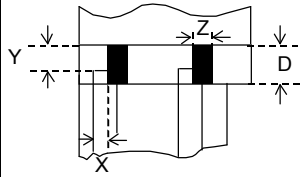
Defect	Inspection Item	Inspection Standards		
Minor	Tilted soldering	Within the angle +5°		Acceptable
Minor	Uneven solder joint /bump			Reject
Minor	Hole $\Phi = \frac{L + W}{2}$	Expose the conductive line		Reject
		$\Phi > 1.0\text{mm}$		Reject
Minor	Position shift 	Y > 1/3D		Reject
		X > 1/2Z		Reject

MODEL

SD1022-V00

11/17

PRODUCT SPECIFICATIONS

REV: C

9. QUALITY SPECIFICATION (Continued)

9-4. Criteria (Continued)

5. Screw

Defect	Inspection Item	Inspection Standards	
Major	Screw missing/loosen		Reject
Minor	Screw oxidation	Any rust	Reject
Minor	Screw deformation	Difficult to accept screw driver	Reject

6. Heatseal 、TCP 、FPC

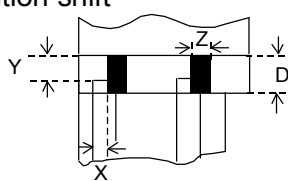
Defect	Inspection Item	Inspection Standards	
Major	Scratch expose conductive layer		Reject
Minor	HS Hole $\Phi = \frac{L + W}{2}$	$\Phi > 0.5\text{mm}$	Reject
Major	Adhesion strength	Less than the specification	Reject
Minor	Position shift 	$Y > 1/3D$	Reject
		$X > 1/2Z$	Reject
Major	Conductive line break		Reject

7. LED Backing Protective Film and Others

Defect	Inspection Item	Inspection Standards	
Minor	LED dirty, prick	Acceptable number of units	
		$\Phi \leq 0.10\text{mm}$	Ignore
		$0.10 < \Phi \leq 0.15\text{mm}$	2
		$0.15 < \Phi \leq 0.2\text{mm}$	1
		$\Phi > 0.2\text{mm}$	0
		The distance between any two spots should be $\geq 5\text{mm}$ Any spot/dot/void outside of viewing area is acceptable	
Minor	Protective film tilt	Not fully cover LCD	Reject
Major	COG coating	Not fully cover ITO circuit	Reject

8. Electric Inspection

Defect	Inspection Item	Inspection Standards	
Major	Short		Reject
Major	Open		Reject

MODEL	SD1022-V00	12/17	PRODUCT SPECIFICATIONS	REV: C
-------	------------	-------	------------------------	--------

9. QUALITY SPECIFICATION (Continued)

9-4. Criteria (Continued)

9. Inspection Specification of LCD

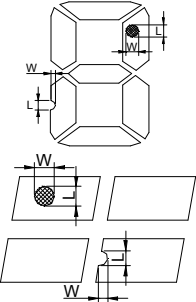
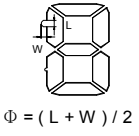
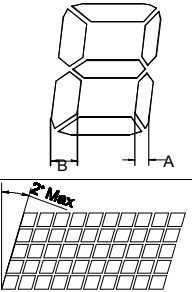
Defect	Inspect Item		Inspection Standards				
			W	W \leq 0.03	0.03<W \leq 0.05	W>0.05	
Minor	Linear Defect	<ul style="list-style-type: none"> * Glass Scratch * Polarizer Scratch * Fiber and Linear material 	L	L<5	L<3	Any	
			ACC. NO.	1	1	Reject	
			Note	L is the length and W is the width of the defect			
Minor	Black Spot and Polarizer Pricked	<ul style="list-style-type: none"> * Foreign material between glass and polarizer or glass and glass * Polarizer hole or protuberance by external force 	Φ	$\Phi\leq 0.1$	$0.1<\Phi\leq 0.15$	$0.15<\Phi\leq 0.2$	$\Phi>0.2$
			ACC. NO.	3EA / 100mm ²	2	1	0
			Note	Φ is the average diameter of the defect. Distance between two defects > 10mm.			
Minor	White Spot and Bubble in polarizer	<ul style="list-style-type: none"> * Unobvious transparent foreign material between glass and glass or glass and polarizer * Air protuberance between polarizer and glass 	Φ	$\Phi\leq 0.3$	$0.3<\Phi\leq 0.5$	$0.5<\Phi$	
			ACC. NO.	3EA / 100mm ²	1	0	
			Note	Φ is the average diameter of the defect. Distance between two defects > 10mm.			
Minor	Segment Defect		Φ	$\Phi\leq 0.10$	$0.10<\Phi\leq 0.20$	$0.20<\Phi\leq 0.25$	$\Phi>0.25$
			ACC. NO.	3EA / 100mm ²	2	1	0
			Note	W is more than 1/2 segment width			
			Note	$\Phi = \frac{L + W}{2}$ Distance between two defect is 10mm			
Minor	Protuberant Segment		Φ	$\Phi\leq 0.10$	$0.10<\Phi\leq 0.20$	$0.20<\Phi\leq 0.25$	$\Phi>0.25$
			W	Glue	$W\leq 1/2$ Seg $W\leq 0.2$	$W\leq 1/2$ Seg $W\leq 0.2$	Ignore
			ACC. NO.	3EA / 100mm ²	2	1	0
Minor	Assembly Mis-alignment		1. Segment				
			B	B \leq 0.4mm	$0.4<B\leq 1.0$ mm	B>1.0mm	
			B-A	B-A<1/2B	B-A<0.2	B-A<0.25	
			Judge	Acceptable	Acceptable	Acceptable	
			2. Dot Matrix				
			Deformation>2°				Reject
Minor	Stain on LCD Panel Surface		Accept when stains can be wiped lightly with a soft cloth or a similar one. Otherwise, judged according to the above items: "Black spot" and "White Spot"				

MODEL

SD1022-V00

13/17

PRODUCT SPECIFICATIONS

REV: C

10. RELIABILITY

NO.	Item	Condition	Criterion
1	High Temperature Operating	-20°C , 96Hrs	No defect in cosmetic and operational function allowable.
2	Low Temperature Operating	70°C , 96Hrs	
3	High Humidity	60°C , 90%RH, 96Hrs	
4	High Temperature Storage	80°C , 96Hrs	
5	Low Temperature Storage	-30°C , 96Hrs	
6	Vibration	Random wave 10 ~ 100Hz Acceleration: 2G 60 Minute	Total current Consumption should be below double of initial value.
7	Thermal Shock	-10°C to 25°C to 60°C (60Min) (15Min) (60Min) 10Cycles	
8	ESD Testing	Contract Discharge Voltage: +1 ~ 5kV and -1 ~ -5kV	There will be discharged ten times at every discharging voltage cycle. The voltage gap is 1kV.
		Air Discharge Voltage: +1 ~ 8kV and -1 ~ -8kV	

- Note:
- 1) Above conditions are suitable for Swissdis standard products.
 - 2) For restrict products, the test conditions listed as above must be revised.

MODEL	SD1022-V00	14/17	PRODUCT SPECIFICATIONS	REV: C
--------------	-------------------	--------------	-------------------------------	---------------

11. HANDLING PRECAUTION

(1) Mounting Method

The panel of the LCD Module consists of two thin glass plates with polarizers which easily get damaged since the Module is fixed by utilizing fitting holes in the printed circuit board. Extreme care should be taken when handling the LCD Modules.

(2) Caution of LCD handling & cleaning

When cleaning the display surface, use soft cloth with solvent (recommended below) and wipe lightly.

- Isopropyl alcohol
- Ethyl alcohol
- Trichlorotrifluoroethane

Do not wipe the display surface with dry or hard materials that will damage the polarizer surface.

Do not use the following solvent:

- Water
- Ketone
- Aromatics

(3) Caution against static charge

The LCD Module use C-MOS LSI drivers, so we recommend that you connect any unused input terminal to VDD or VSS, do not input any signals before power is turned on. And ground your body, Work/assembly table. And assembly equipment to protect against static electricity.

(4) Packaging

- Modules use LCD elements, and must be treated as such. Avoid intense shock and falls from a height.
- To prevent modules from degradation. Do not operate or store them exposed directly to sunshine or high temperature/humidity.

(5) Caution for operation

- It is indispensable to drive LCD's within the specified voltage limit since the higher voltage than the limit shorten LCD life. An electrochemical reaction due to direct current causes LCD deterioration, Avoid the use of direct current drive.

MODEL	SD1022-V00	15/17	PRODUCT SPECIFICATIONS	REV: C
--------------	-------------------	--------------	-------------------------------	---------------

11. HANDLING PRECAUTION (Continued)

- Response time will be extremely delayed at lower temperature than the operating temperature range and on the other hand at higher temperature LCD's show dark color in them.

However those phenomena do not mean malfunction or out of order with LCD's.

Which will come back in the specified operating temperature range.

- If the display area is pushed hard during operation, some font will be abnormally displayed but it resumes normal condition after turning off once.
- A slight dew depositing on terminals is a cause for electro-chemical reaction resulting in terminal open circuit.

Usage under the relative condition of 40°C, 80%RH or less is required.

(6) Storage

In the case of storing for a long period of time (for instance ,for years) for the purpose or replacement use, The following ways are recommended.

- Storage in a polyethylene bag with sealed so as not to enter fresh air outside in it, And with no desiccant.
- Placing in a dark place where neither exposure to direct sunlight nor light is. Keeping temperature in the specified storage temperature range.
- Storing with no touch on polarizer surface by the anything else. (It is recommended to store them as they have been contained in the inner container at the time of delivery)

(7) Safety

- It is recommendable to crash damaged or unnecessary LCD into pieces and wash off liquid crystal by using solvents such as acetone and ethanol.

Which should be burned up later.

- When any liquid crystal leaked out of a damaged glass cell comes in contact with your hands, please wash it off well with soap and water.

MODEL	SD1022-V00	16/17	PRODUCT SPECIFICATIONS	REV: C
--------------	-------------------	--------------	-------------------------------	---------------

12. OUTLINE DIMENTION

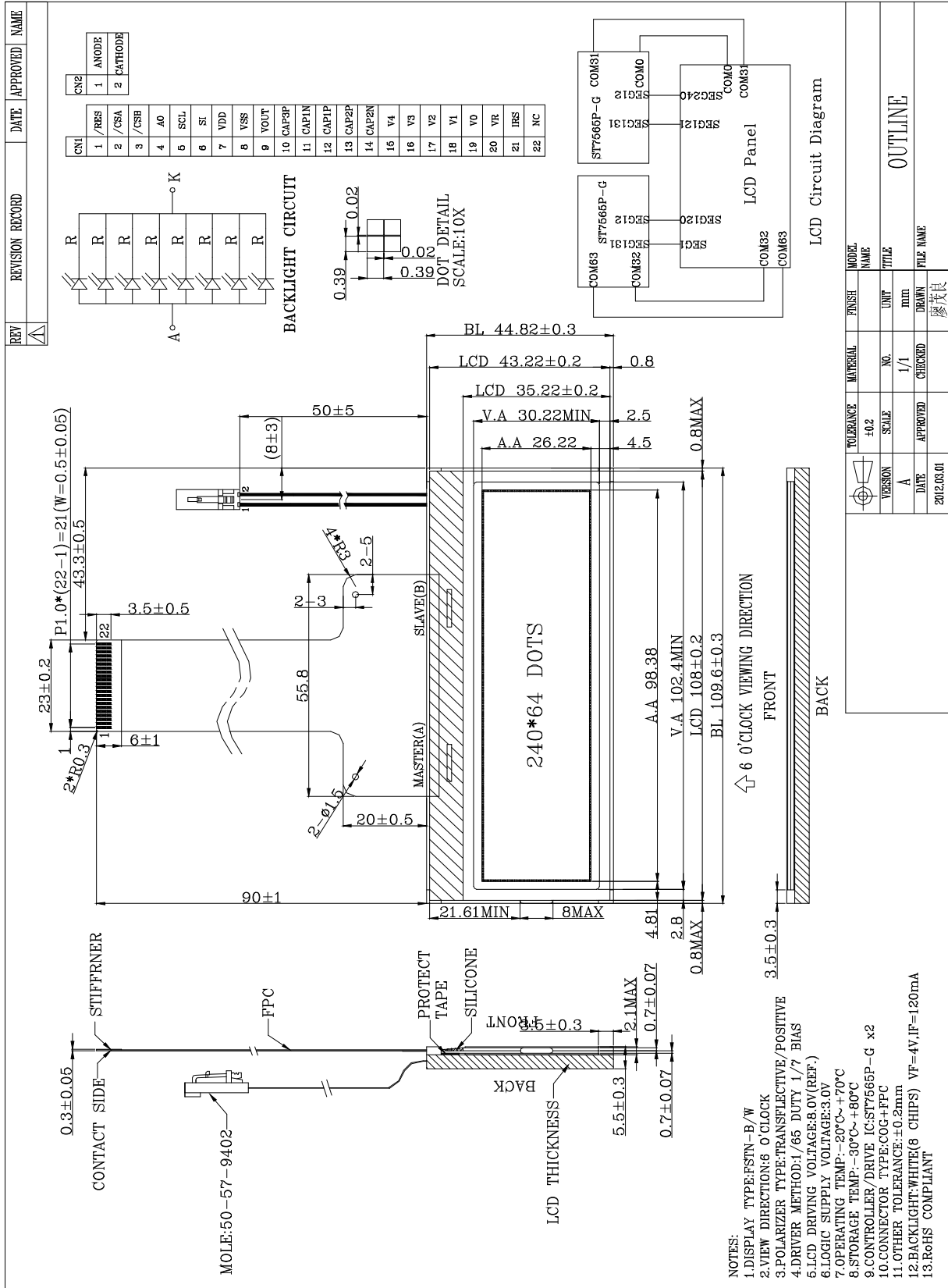

MODEL

SD1022-V00

17/17

PRODUCT SPECIFICATIONS

REV: C

SAMPLE OUTGOING INSPECTION REPORT (LCM)

Data: 2012/11/21

NO. : QAC11002

Customer	Product NO.	Driving Voltage	Testing Condition	Quantity
Swissdis AG	SD1022-V00	V _{OP} : 8.0V	25°C	5Pcs

Inspection Result

Items	Specification
Display Mode	<input checked="" type="radio"/> W / B Mode <input type="radio"/> B / W Mode <input type="radio"/> Yellow Mode <input type="radio"/> Blue Mode <input type="radio"/> Gray Mode
Polarizer Type	<input type="radio"/> Reflective <input checked="" type="radio"/> Transflective <input type="radio"/> Transmissive
Viewing direction	<input type="radio"/> 3 O'clock <input checked="" type="radio"/> 6 O'clock <input type="radio"/> 9 O'clock <input type="radio"/> 12 O'clock

Electrical / Appearance

Item	Inspection Method	Specification	Inspection Result	
Appearance	Spot Gauge Caliper	Final Inspection Criteria	<input checked="" type="radio"/> OK	<input type="radio"/> NG
Electrical	LCM Tester	Product Specification	<input checked="" type="radio"/> OK	<input type="radio"/> NG
Pattern	LCM Tester	Drawing	<input checked="" type="radio"/> OK	<input type="radio"/> NG

Dimension / Supply Current

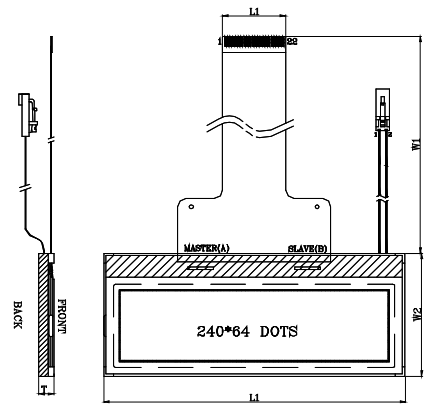
Item	Spec.(mm)	NO.1	NO.2	NO.3	NO.4	NO.5	Result		Fig.
L1	109.6±0.3	109.6	109.7	109.6	109.6	109.5	<input checked="" type="radio"/> OK	<input type="radio"/> NG	
L2	23.0±0.2	22.97	22.92	22.98	22.97	22.95	<input checked="" type="radio"/> OK	<input type="radio"/> NG	
W1	90.0±1.0	89.98	89.72	89.66	89.98	89.95	<input checked="" type="radio"/> OK	<input type="radio"/> NG	
W2	44.82±0.3	44.90	44.89	44.85	44.90	44.85	<input checked="" type="radio"/> OK	<input type="radio"/> NG	
T	5.5±0.3	5.53	5.50	5.48	5.55	5.52	<input checked="" type="radio"/> OK	<input type="radio"/> NG	
I _{DD}	3.0mA max	1.50	1.50	1.50	1.50	1.50	<input checked="" type="radio"/> OK	<input type="radio"/> NG	

Designed	ELIN	Checked	/	Approved	Wallace
----------	------	---------	---	----------	---------