

SWISSDIS



Swissdis AG
Grasweg 7
CH-4911 Schwarzhäusern

Tel.: +41 62 919 44 00
Fax: +41 62 919 44 01
info@swissdis.ch
www.swissdis.ch



SPECIFICATIONS

Multilayer Chip Bead

CB-Serie

Version July 2013

Multilayer Chip Beads



■ Features

- Effective EMI protection
- Low DC resistance
- High soldering heat resistance
- Multiple size availability

■ Applications

- Computers and Peripheral Equipment
- VCRS, Television, Pagers
- Cellular Phones
- Digital Communication Equipment
- Various Electronics Equipments
- Circuit Where a Stable Ground is Unavailable

■ Construction

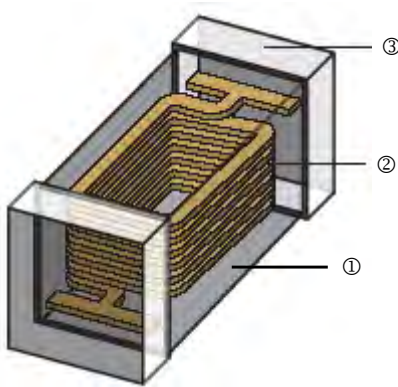

① Ferrite	② Internal Electrode	③ Electrode Plating (Ag/Ni/Sn)
-----------	----------------------	--------------------------------

■ Dimensions

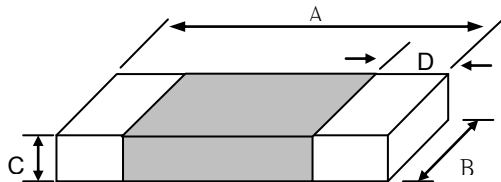

Unit : mm

Type	Size (Inch)	A	B	C	D	Weight (g) (1000pcs)
CB02	0402	1.0±0.10	0.50±0.10	0.5±0.10	0.1~0.35	2.6
CB03	0603	1.6±0.20	0.80±0.15	0.8±0.15	0.1~0.6	6.2
CB05	0805	2.0±0.20	1.25±0.20	0.9±0.20	0.2~0.8	10
CB04	1204	3.2±0.20	1.60±0.20	1.1±0.20	0.2~1.0	30
CB06	1206	3.2±0.20	1.60±0.20	1.6±0.20	0.2~1.0	42
CB10	1210	3.2±0.20	2.50±0.20	1.3±0.20	0.2~1.0	54
CB08	1808	4.5±0.25	1.60±0.20	1.6±0.20	0.2~1.0	60
CB12	1812	4.5±0.25	3.20±0.20	1.5±0.20	0.2~1.0	62

Multilayer Chip Beads

Part Numbering

CB	03	Y	T	Y	N	601
Product Type	Dimensions	Impedance Tolerance	Packaging Code	Design Code	Current	Impedance
	02: 0402 03: 0603 05: 0805 04: 1204 06: 1206 10: 1210 08: 1808 12: 1812	Y: $\pm 25\%$	T: Taping Reel	Y: ui:200 Q: ui:75(High Speed Signals)	H: High current N: General current	090: 9 Ω 110: 11 Ω 451: 450 Ω 152: 1500 Ω

Standard Electrical Specifications

CB02(100505) / Standard Type

Impedance (Ω)	Tolerance	Test Freq. (MHz)	DCR (Ω) max.	Rated Current (mA) max.
6	$\pm 25\%$	100	0.05	500
10	$\pm 25\%$	100	0.05	500
30	$\pm 25\%$	100	0.30	300
33	$\pm 25\%$	100	0.30	300
40	$\pm 25\%$	100	0.30	300
47	$\pm 25\%$	100	0.40	300
60	$\pm 25\%$	100	0.40	300
70	$\pm 25\%$	100	0.40	300
75	$\pm 25\%$	100	0.40	300
80	$\pm 25\%$	100	0.40	300
90	$\pm 25\%$	100	0.50	300
100	$\pm 25\%$	100	0.50	300
120	$\pm 25\%$	100	0.50	300
150	$\pm 25\%$	100	0.50	300
220	$\pm 25\%$	100	0.50	300
240	$\pm 25\%$	100	0.50	300
300	$\pm 25\%$	100	0.80	300
330	$\pm 25\%$	100	0.80	300
480	$\pm 25\%$	100	0.80	300
600	$\pm 25\%$	100	1.00	300
1000	$\pm 25\%$	100	1.50	100
1500	$\pm 25\%$	100	2.00	60

Multilayer Chip Beads

■ Standard Electrical Specifications

CB03(160808) / Standard Type

Impedance (Ω)	Tolerance	Test Frequency (MHz)	DCR (Ω) max.	Rated Current (mA) max.
6	±25%	100	0.05	500
7	±25%	100	0.05	500
10	±25%	100	0.05	500
11	±25%	100	0.05	500
15	±25%	100	0.08	500
17	±25%	100	0.08	500
19	±25%	100	0.08	500
20	±25%	100	0.10	400
22	±25%	100	0.10	400
25	±25%	100	0.10	400
26	±25%	100	0.10	400
30	±25%	100	0.10	400
31	±25%	100	0.10	400
32	±25%	100	0.10	400
33	±25%	100	0.10	400
40	±25%	100	0.10	400
47	±25%	100	0.10	400
50	±25%	100	0.10	400
52	±25%	100	0.10	400
55	±25%	100	0.10	400
56	±25%	100	0.10	400
60	±25%	100	0.10	400
68	±25%	100	0.15	400
70	±25%	100	0.15	400
75	±25%	100	0.15	400
80	±25%	100	0.15	400
90	±25%	100	0.20	400
100	±25%	100	0.20	400
120	±25%	100	0.25	400
140	±25%	100	0.25	300
150	±25%	100	0.30	200
180	±25%	100	0.30	200
200	±25%	100	0.30	200
220	±25%	100	0.30	200
240	±25%	100	0.40	200
300	±25%	100	0.40	200
330	±25%	100	0.50	200
400	±25%	100	0.50	200
420	±25%	100	0.50	200
450	±25%	100	0.50	200
470	±25%	100	0.50	200
500	±25%	100	0.50	200
600	±25%	100	0.50	200
750	±25%	100	0.70	200
800	±25%	100	0.70	200
1000	±25%	100	0.70	200
1200	±25%	100	1.00	50
1500	±25%	100	1.00	50
1700	±25%	100	1.20	50
2000	±25%	100	1.20	50
2200	±25%	100	1.20	50
2500	±25%	100	1.30	50
2700	±25%	100	1.30	50

Multilayer Chip Beads

■ Standard Electrical Specifications

CB05(201209) / Standard Type

Impedance (Ω)	Tolerance	Test Frequency (MHz)	DCR (Ω) max.	Rated Current (mA) max.
5	±25%	100	0.10	600
7	±25%	100	0.10	600
9	±25%	100	0.10	600
10	±25%	100	0.10	600
11	±25%	100	0.10	600
12	±25%	100	0.10	600
15	±25%	100	0.10	600
17	±25%	100	0.10	600
19	±25%	100	0.10	600
22	±25%	100	0.10	600
26	±25%	100	0.10	600
28	±25%	100	0.10	600
30	±25%	100	0.10	600
31	±25%	100	0.10	600
32	±25%	100	0.10	600
33	±25%	100	0.10	500
39	±25%	100	0.10	500
40	±25%	100	0.10	500
42	±25%	100	0.10	500
47	±25%	100	0.10	500
50	±25%	100	0.10	500
52	±25%	100	0.15	500
56	±25%	100	0.15	500
60	±25%	100	0.15	500
70	±25%	100	0.15	500
75	±25%	100	0.15	500
80	±25%	100	0.15	500
90	±25%	100	0.15	500
95	±25%	100	0.15	500
100	±25%	100	0.25	300
120	±25%	100	0.25	300
150	±25%	100	0.25	300
180	±25%	100	0.30	300
200	±25%	100	0.30	300
220	±25%	100	0.3	300
240	±25%	100	0.3	300
300	±25%	100	0.3	300
330	±25%	100	0.3	300
400	±25%	100	0.3	300
420	±25%	100	0.3	300
430	±25%	100	0.4	300
450	±25%	100	0.4	300
470	±25%	100	0.4	300
500	±25%	100	0.4	300
600	±25%	100	0.4	300
680	±25%	100	0.4	300
750	±25%	100	0.5	200
1000	±25%	100	0.5	200
1200	±25%	100	0.6	200
1500	±25%	100	0.6	200
2000	±25%	100	0.7	200
2200	±25%	100	0.7	200
2500	±25%	100	0.7	200
2700	±25%	100	0.7	200

Multilayer Chip Beads

■ Standard Electrical Specifications

CB04(321611) / Standard Type

Impedance (Ω)	Tolerance	Test Frequency (MHz)	DCR (Ω) max.	Rated current (mA) max.
8	±25%	100	0.05	600
9	±25%	100	0.05	600
11	±25%	100	0.05	600
17	±25%	100	0.05	600
19	±25%	100	0.05	600
22	±25%	100	0.05	600
24	±25%	100	0.05	600
26	±25%	100	0.05	600
30	±25%	100	0.05	600
31	±25%	100	0.05	600
32	±25%	100	0.05	600
33	±25%	100	0.05	600
35	±25%	100	0.10	500
47	±25%	100	0.10	500
50	±25%	100	0.10	500
52	±25%	100	0.10	500
60	±25%	100	0.10	500
70	±25%	100	0.10	500
75	±25%	100	0.15	500
80	±25%	100	0.15	500
90	±25%	100	0.15	500
100	±25%	100	0.15	500
120	±25%	100	0.15	500
150	±25%	100	0.15	500
180	±25%	100	0.20	400
200	±25%	100	0.20	400
220	±25%	100	0.20	400
240	±25%	100	0.20	400
300	±25%	100	0.20	400
400	±25%	100	0.20	400
470	±25%	100	0.20	400
500	±25%	100	0.20	400
600	±25%	100	0.30	400
700	±25%	100	0.40	200
1000	±25%	50	0.40	200
1200	±25%	50	0.40	200
1500	±25%	50	0.45	200
2000	±25%	30	0.60	200
2700	±25%	30	0.60	200

Multilayer Chip Beads**■ Standard Electrical Specifications**

CB06(321616) / Standard Type

Impedance (Ω)	Tolerance	Test Frequency (MHz)	DCR (Ω) max.	Rated Current (mA) max.
25	±25%	100	0.10	500
60	±25%	100	0.20	500
70	±25%	100	0.20	500

CB10(322513) / Standard Type

Impedance (Ω)	Tolerance	Test Frequency (MHz)	DCR (Ω) max.	Rated Current (mA) max.
32	±25%	100	0.20	500
60	±25%	100	0.20	500
90	±25%	100	0.20	500
120	±25%	100	0.20	500

CB08(451616) / Standard Type

Impedance (Ω)	Tolerance	Test Frequency (MHz)	DCR (Ω) max.	Rated Current (mA) max.
33	±25%	100	0.20	600
50	±25%	100	0.20	600
60	±25%	100	0.20	600
80	±25%	100	0.20	600
90	±25%	100	0.30	500
100	±25%	100	0.30	500
150	±25%	100	0.30	500
170	±25%	100	0.30	500

CB12(453215) / Standard Type

Impedance (Ω)	Tolerance	Test Frequency (MHz)	DCR (Ω) max.	Rated Current (mA) max.
70	±25%	100	0.30	500
120	±25%	100	0.30	500

Multilayer Chip Beads

■ Standard Electrical Specifications(for High Current Use)

CB02(100505) / High Current Type

Impedance (Ω)	Tolerance	Test Frequency (MHz)	DCR (Ω) max.	Rated Current (mA) max.
10	±25%	100	0.030	1000

CB03(160808) / High Current Type

Impedance (Ω)	Tolerance	Test Frequency (MHz)	DCR (Ω) max.	Rated Current (mA) max.
10	±25%	100	0.020	4000
11	±25%	100	0.020	4000
15	±25%	100	0.030	3000
17	±25%	100	0.030	3000
19	±25%	100	0.030	3000
20	±25%	100	0.030	3000
22	±25%	100	0.030	3000
25	±25%	100	0.030	3000
30	±25%	100	0.030	3000
31	±25%	100	0.030	3000
32	±25%	100	0.035	3000
33	±25%	100	0.035	3000
40	±25%	100	0.035	3000
47	±25%	100	0.040	3000
50	±25%	100	0.040	3000
56	±25%	100	0.040	3000
60	±25%	100	0.040	3000
68	±25%	100	0.050	2500
70	±25%	100	0.050	2500
75	±25%	100	0.050	2500
80	±25%	100	0.050	2500
90	±25%	100	0.050	2500
100	±25%	100	0.050	2500
120	±25%	100	0.080	2500
150	±25%	100	0.085	2000
180	±25%	100	0.090	2000
200	±25%	100	0.095	2000
220	±25%	100	0.100	2000
240	±25%	100	0.120	1500
300	±25%	100	0.120	1500
330	±25%	100	0.120	1500
400	±25%	100	0.120	1500
450	±25%	100	0.150	1500
470	±25%	100	0.150	1500
500	±25%	100	0.150	1500
600	±25%	100	0.200	1000
700	±25%	100	0.250	800
750	±25%	100	0.250	800
800	±25%	100	0.250	800
1000	±25%	100	0.250	800
1500	±25%	100	0.400	500

Multilayer Chip Beads

■ Standard Electrical Specifications(for High Current Use)

CB05(201209) / High Current Type

Impedance (Ω)	Tolerance	Test Frequency (MHz)	DCR (Ω) max.	Rated Current (mA) max.
11	±25%	100	0.010	6000
13	±25%	100	0.020	5000
15	±25%	100	0.020	5000
17	±25%	100	0.020	5000
19	±25%	100	0.020	4000
22	±25%	100	0.020	4000
26	±25%	100	0.020	4000
28	±25%	100	0.020	4000
30	±25%	100	0.020	4000
31	±25%	100	0.020	4000
32	±25%	100	0.020	4000
39	±25%	100	0.020	3000
40	±25%	100	0.020	3000
42	±25%	100	0.025	3000
50	±25%	100	0.025	3000
60	±25%	100	0.030	3000
70	±25%	100	0.040	3000
75	±25%	100	0.040	3000
80	±25%	100	0.040	3000
90	±25%	100	0.040	3000
100	±25%	100	0.040	3000
120	±25%	100	0.040	3000
130	±25%	100	0.050	2500
150	±25%	100	0.050	2500
180	±25%	100	0.050	2500
200	±25%	100	0.050	2500
220	±25%	100	0.080	2000
240	±25%	100	0.080	2000
250	±25%	100	0.080	2000
300	±25%	100	0.080	2000
330	±25%	100	0.080	2000
390	±25%	100	0.100	2000
400	±25%	100	0.100	2000
450	±25%	100	0.100	2000
470	±25%	100	0.100	2000
500	±25%	100	0.100	2000
600	±25%	100	0.100	2000
750	±25%	100	0.120	1500
1000	±25%	100	0.120	1500
1500	±25%	100	0.300	1000

Multilayer Chip Beads

■ Standard Electrical Specifications(for High Current Use)

CB04(321611) / High Current Type

Impedance (Ω)	Tolerance	Test Frequency (MHz)	DCR (Ω) max.	Rated Current (mA) max.
7	±25%	100	0.015	6000
8	±25%	100	0.015	6000
11	±25%	100	0.015	6000
19	±25%	100	0.015	6000
26	±25%	100	0.015	6000
30	±25%	100	0.015	4000
31	±25%	100	0.015	4000
32	±25%	100	0.015	4000
35	±25%	100	0.015	4000
40	±25%	100	0.015	4000
42	±25%	100	0.015	4000
48	±25%	100	0.020	4000
50	±25%	100	0.020	4000
52	±25%	100	0.020	4000
60	±25%	100	0.020	4000
68	±25%	100	0.020	4000
70	±25%	100	0.020	4000
75	±25%	100	0.025	3000
80	±25%	100	0.025	3000
90	±25%	100	0.030	3000
100	±25%	100	0.030	2500
120	±25%	100	0.030	2500
150	±25%	100	0.040	2000
200	±25%	100	0.050	2000
220	±25%	100	0.050	2000
300	±25%	100	0.060	2000
330	±25%	100	0.060	2000
390	±25%	100	0.060	2000
400	±25%	100	0.100	2000
500	±25%	100	0.100	2000
600	±25%	100	0.100	2000
1000	±25%	50	0.150	1200
1200	±25%	50	0.180	1000
1500	±25%	50	0.200	800

CB10(322513) / High Current Type

Impedance (Ω)	Tolerance	Test Frequency (MHz)	DCR (Ω) max.	Rated Current (mA) max.
19	±25%	100	0.025	4000
32	±25%	100	0.025	4000
60	±25%	100	0.025	4000
90	±25%	100	0.025	3000

Multilayer Chip Beads

■ Standard Electrical Specifications(for High Current Use)

CB08(451616) / High Current Type

Impedance (Ω)	Tolerance	Test Frequency (MHz)	DCR (Ω) max.	Rated Current (mA) max.
19	±25%	100	0.020	6000
40	±25%	100	0.020	6000
50	±25%	100	0.020	6000
60	±25%	100	0.020	5000
70	±25%	100	0.025	5000
75	±25%	100	0.025	5000
80	±25%	100	0.025	4000
90	±25%	100	0.100	2000
100	±25%	100	0.100	2000
150	±25%	100	0.100	2000
190	±25%	100	0.100	2000
300	±25%	100	0.100	2000
470	±25%	100	0.100	2000
600	±25%	100	0.100	2000
850	±25%	100	0.100	2000
1000	±25%	100	0.100	2000
1300	±25%	100	0.100	2000

CB12(453215) / High Current Type

Impedance (Ω)	Tolerance	Test Frequency (MHz)	DCR (Ω) max.	Rated Current (mA) max.
19	±25%	100	0.030	6000
30	±25%	100	0.030	6000
47	±25%	100	0.030	6000
50	±25%	100	0.030	6000
60	±25%	100	0.030	6000
70	±25%	100	0.030	6000
80	±25%	100	0.030	4000
90	±25%	100	0.030	4000
120	±25%	100	0.030	4000
125	±25%	100	0.030	4000
150	±25%	100	0.030	4000
190	±25%	100	0.030	4000

Multilayer Chip Beads

■ Standard Electrical Specifications (for High Speed Signals Use)

CB02(100505) / High Speed Signals Type

Impedance (Ω)	Tolerance	Test Frequency (MHz)	DCR (Ω) max.	Rated Current (mA) max.
6	±25%	100	0.08	300
10	±25%	100	0.10	300
22	±25%	100	0.25	300
26	±25%	100	0.25	300
30	±25%	100	0.25	300
40	±25%	100	0.25	350
75	±25%	100	0.30	300
80	±25%	100	0.30	300
100	±25%	100	0.40	300
120	±25%	100	0.40	300
220	±25%	100	0.60	200

CB03(160808) / High Speed Signals Type

Impedance (Ω)	Tolerance	Test Frequency (MHz)	DCR (Ω) max.	Rated Current (mA) max.
6	±25%	100	0.05	500
7	±25%	100	0.05	400
10	±25%	100	0.07	400
19	±25%	100	0.20	300
20	±25%	100	0.20	300
22	±25%	100	0.20	300
30	±25%	100	0.20	300
40	±25%	100	0.20	300
47	±25%	100	0.20	300
50	±25%	100	0.25	300
60	±25%	100	0.25	300
68	±25%	100	0.25	300
70	±25%	100	0.25	300
75	±25%	100	0.25	300
80	±25%	100	0.25	300
100	±25%	100	0.30	300
120	±25%	100	0.30	300
130	±25%	100	0.30	300
140	±25%	100	0.30	300
150	±25%	100	0.30	200
160	±25%	100	0.30	200
180	±25%	100	0.35	200
200	±25%	100	0.35	200
220	±25%	100	0.35	200
240	±25%	100	0.35	200
300	±25%	100	0.40	200
400	±25%	100	0.50	200
420	±25%	100	0.50	200
470	±25%	100	0.50	200
480	±25%	100	0.50	200
600	±25%	100	0.50	200
1000	±25%	100	0.60	100
1200	±25%	100	0.60	100
1500	±25%	100	0.70	100
1800	±25%	100	0.80	100
2200	±25%	100	1.00	50
2500	±25%	100	1.50	50

Multilayer Chip Beads

■ Standard Electrical Specifications(for High Speed Signals Use)

CB05(201209) / High Speed Signals Type

Impedance (Ω)	Tolerance	Test Frequency (MHz)	DC Resistance (Ω) max.	Rated current (mA) max.
5	±25%	100	0.07	800
6	±25%	100	0.07	800
7	±25%	100	0.10	700
11	±25%	100	0.10	700
26	±25%	100	0.15	600
30	±25%	100	0.15	600
32	±25%	100	0.15	600
40	±25%	100	0.15	500
60	±25%	100	0.15	500
70	±25%	100	0.15	500
75	±25%	100	0.15	500
90	±25%	100	0.15	500
100	±25%	100	0.20	400
120	±25%	100	0.20	400
150	±25%	100	0.20	400
170	±25%	100	0.30	400
200	±25%	100	0.30	300
220	±25%	100	0.30	300
240	±25%	100	0.30	300
300	±25%	100	0.30	300
400	±25%	100	0.30	300
420	±25%	100	0.30	300
470	±25%	100	0.35	200
500	±25%	100	0.35	200
600	±25%	100	0.35	200
750	±25%	100	0.40	200
1000	±25%	100	0.40	200
1200	±25%	100	0.45	200
1500	±25%	100	0.45	200
2000	±25%	100	0.50	200
2200	±25%	100	0.50	200
2500	±25%	100	0.60	200
2700	±25%	100	0.60	200

Multilayer Chip Beads

Standard Electrical Specifications(for High Speed Signals Use)

CB04(321611) / High Speed Signals Type

Impedance (Ω)	Tolerance	Test Frequency (MHz)	DCR (Ω) max.	Rated Current (mA) max.
15	±25%	100	0.15	600
17	±25%	100	0.15	600
19	±25%	100	0.15	600
30	±25%	100	0.15	600
32	±25%	100	0.15	600
50	±25%	100	0.15	500
60	±25%	100	0.15	500
80	±25%	100	0.15	500
90	±25%	100	0.15	500
120	±25%	100	0.20	400
150	±25%	100	0.20	400
200	±25%	100	0.25	300
220	±25%	100	0.30	300
300	±25%	100	0.30	300
350	±25%	100	0.30	300
400	±25%	100	0.30	300
600	±25%	100	0.35	300
1000	±25%	100	0.40	200
1200	±25%	100	0.40	200
1500	±25%	100	0.45	200

Soldering Condition

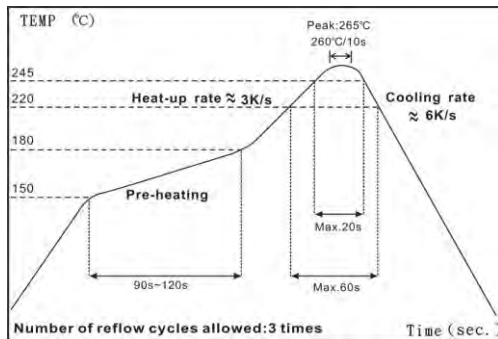

IR Reflow Soldering

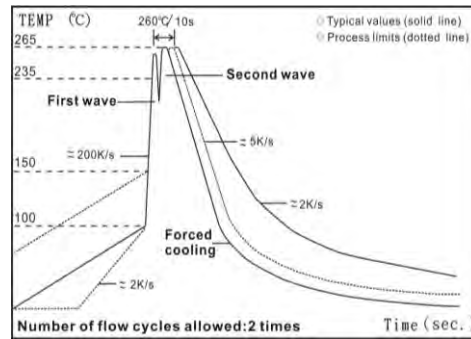

Wave Soldering (Flow Soldering)

- (1) Time of IR reflow soldering at maximum temperature point 260°C : 10s
- (2) Time of wave soldering at maximum temperature point 260°C : 10s
- (3) Time of soldering iron at maximum temperature point 410°C : 5s



Multilayer Chip Beads

■ Environmental Characteristics

Electrical Performance Test

Item	Specification	Test Methods
Impedance	Refer to standard electrical spec.	HP4291B
DCR		Agilent 34401A

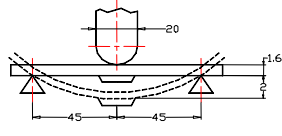
Mechanical Performance Test

Item	Specification	Test Methods
Flexure Strength	The forces applied on the right conditions must not damage the terminal electrode and the ferrite	Test device shall be soldered on the substrate Substrate Dimension:100x40x1.6mm Deflection: 2.0mm Keeping Time: 30sec 
Vibration		Test device shall be soldered on the substrate Oscillation Frequency : 10 to 55 to 10Hz for 1min Amplitude : 1.5mm Time : 2hrs for each axis (X,Y&Z), total 6hrs
Resistance to Soldering Heat	Appearance: No damage More than 75% of the terminal electrode should be covered with solder Impedance: within $\pm 30\%$ of initial value	Pre-heating: 150°C, 1min Solder Temperature: 260 \pm 5°C Immersion Time: 10 \pm 1sec
Solderability	The electrodes shall be at least 90% covered with new solder coating	Pre-heating: 150°C, 1min Solder Temperature: 245 \pm 5°C Immersion Time: 4 \pm 1sec
Terminal Strength Test	0402 series : ≥ 0.2 kg 0603series : ≥ 0.5 kg 0805 series : ≥ 1.0 kg other series : ≥ 2.0 kg	Test device shall be soldered on the substrate 
Temperature Cycle	Appearance: No damage Impedance: within $\pm 30\%$ of initial value	One cycle: One cycle/step1: -55 \pm 3°C for 30min step2: 25 \pm 2°C for 3.0min step3:125 \pm 3°C for 30min step4:25 \pm 2°C for 3.0min Total: 100cycles Measured after exposure in the room condition for 24hrs
Humidity Resistance		Temperature: 40 \pm 2°C Relative Humidity: 90 ~ 95% time: 1000hrs Measured after exposure in the room condition for 24hrs
High Temperature Resistance		Temperature: 125 \pm 3°C Relative Humidity : 0% Applied Current: Rated Current time: 1000hrs Measured after exposure in the room condition for 24hrs
Low Temperature Resistance		Temperature: -55 \pm 3°C TR elative Humidity : 0% time: 1000hrs Measured after exposure in the room condition for 24hrs

■ Operating Temperature: -55°C ~ 125°C

■ Storage Temperature: 25 \pm 3°C ; Humidity < 80%RH

Multilayer Chip Beads

■ Packaging

Reel Specifications

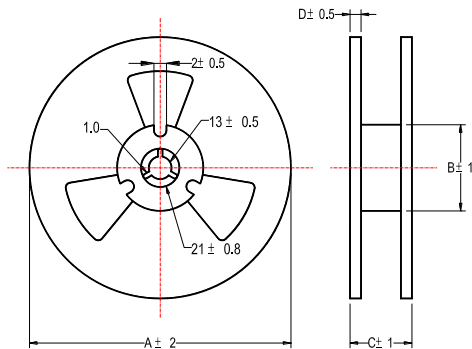

Tape Specifications

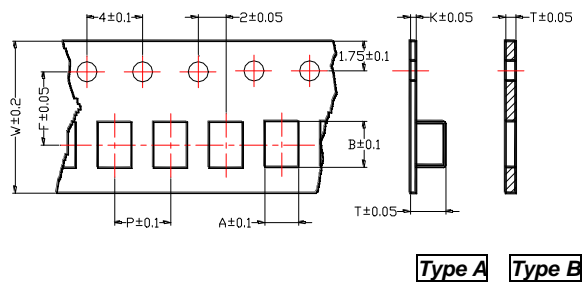

Tape Material

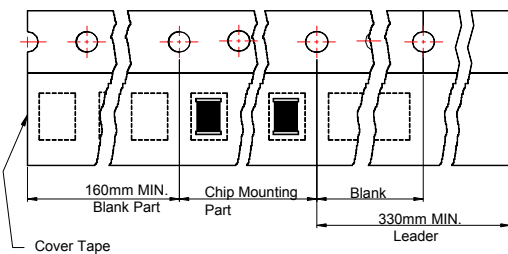

Recommended Pattern

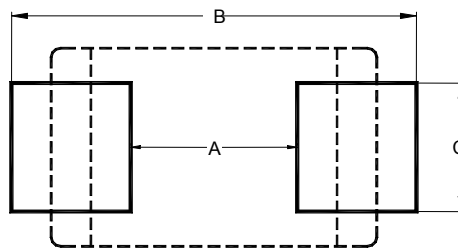

- Don't apply narrower pattern than listed above to CB□□YTYH .
Narrow pattern might cause excessive heat or open circuit.

Unit : mm

Type	Tape Dimensions								Reel Dimensions				Recommended Pattern			Quantity (EA)
	A	B	T	W	P	F	K	Tape Type	A	B	C	D	A	B	C	
CB02	0.65	1.15	0.7	8.0	2.0	3.5	-	B	178	60	10	2	0.4	1.2 ~ 1.4	0.4	10000
CB03	1.10	1.85	0.95	8.0	4.0	3.5	-	B	178	60	10	2	0.8	2.4 ~ 3.4	0.6	4000
CB05	1.58	2.42	0.95	8.0	4.0	3.5	-	B	178	60	10	2	1.2	3.0 ~ 4.0	1.0	4000
CB03	1.05	1.95	1.05	8.0	4.0	3.5	0.23	A	178	60	10	2	0.8	2.4 ~ 3.4	0.6	4000
CB05	1.42	2.25	1.04	8.0	4.0	3.5	0.22	A	178	60	10	2	1.2	3.0 ~ 4.0	1.0	4000
CB04	1.88	3.50	1.27	8.0	4.0	3.5	0.2	A	178	60	10	2	2.0	4.2 ~ 5.2	1.2	3000
CB06	1.88	3.64	1.90	8.0	4.0	3.5	0.2	A	178	60	10	2	2.0	4.2 ~ 5.2	1.2	2000
CB10	2.77	3.42	1.65	8.0	4.0	3.5	0.2	A	178	60	10	2	2.0	5.5 ~ 6.5	1.8	2000
CB08	1.88	4.95	1.90	12	4.0	5.5	0.3	A	178	60	14	2	3.0	5.5 ~ 6.5	1.2	2000
CB12	3.66	4.95	1.85	12	8.0	5.5	0.3	A	178	60	14	2	3.0	5.5 ~ 6.5	2.4	1000

Characteristics (Impedance vs. Frequency) - - CB02YTYN

CB02YTYN100

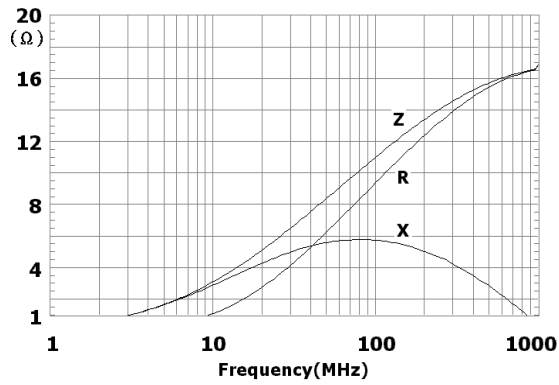

CB02YTYN300

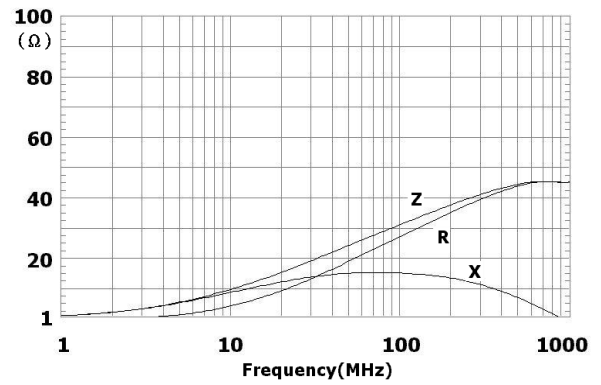

CB02YTYN400

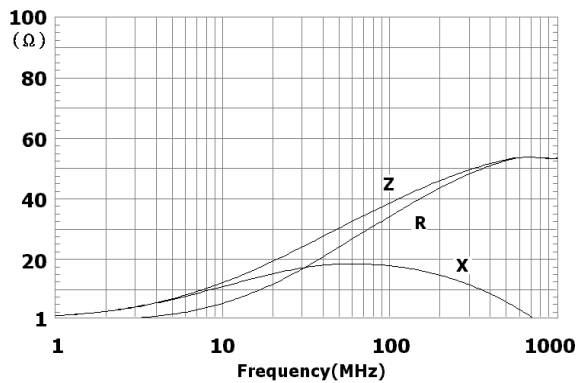

CB02YTYN600

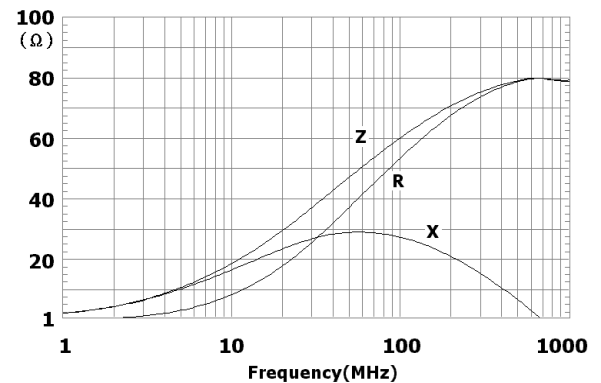

CB02YTYN700

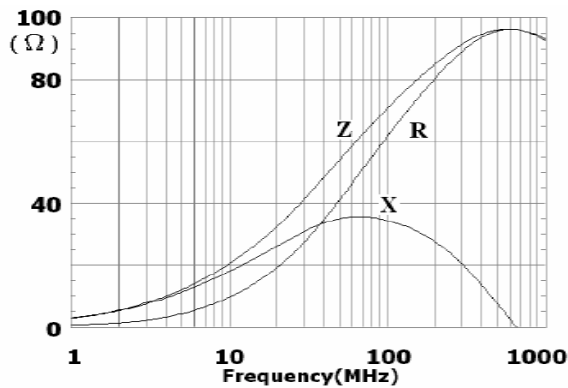

CB02YTYN750

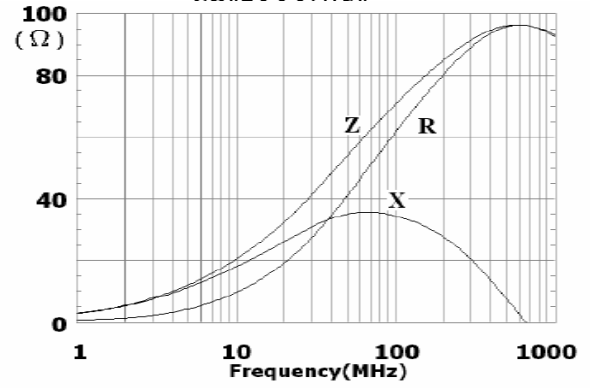

CB02YTYN800

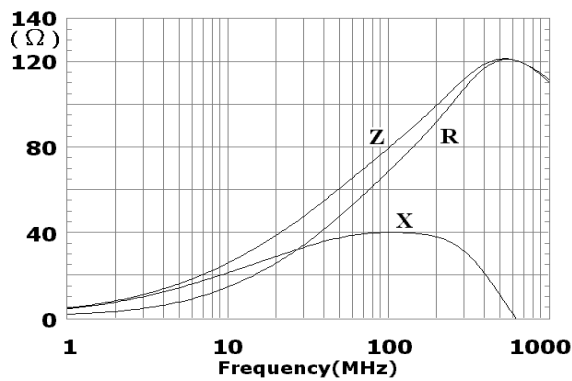

CB02YTYN900

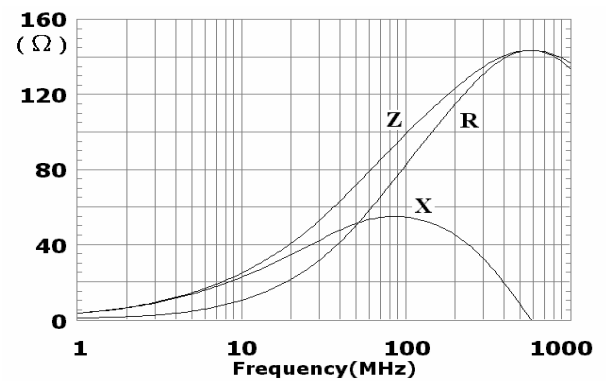

CB02YTYN101

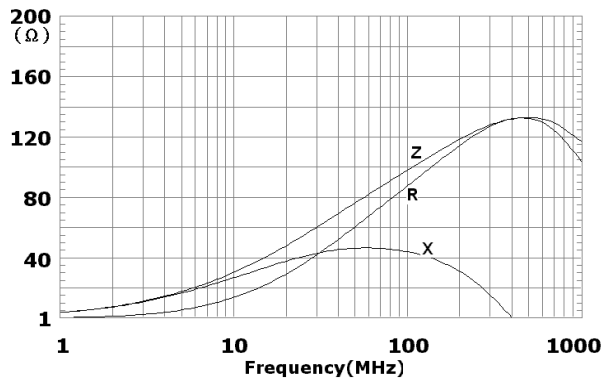

CB02YTYN121

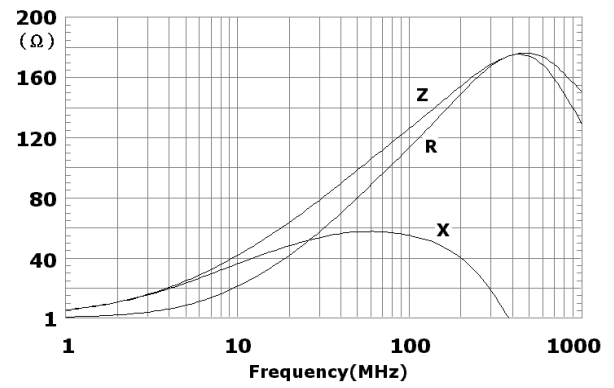

CB02YTYN151

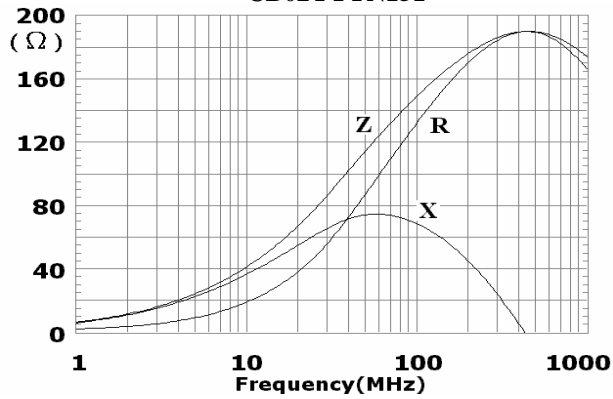

CB02YTYN221

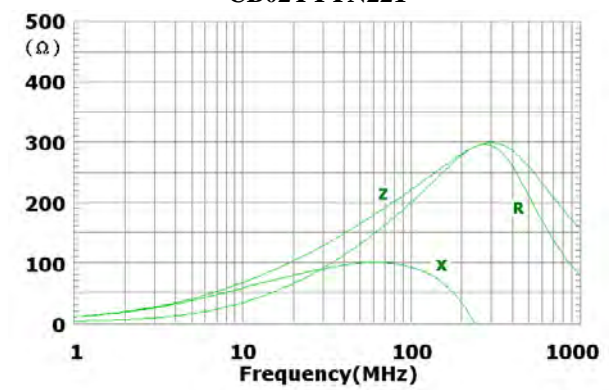

CB02YTYN241

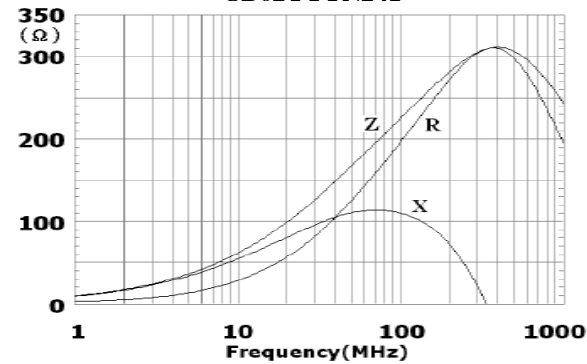

CB02YTYN301

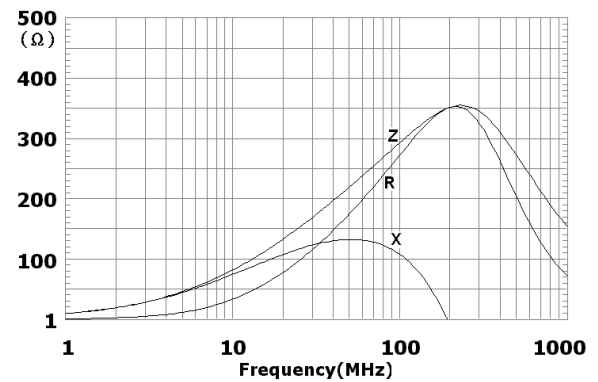

CB02YTYN331

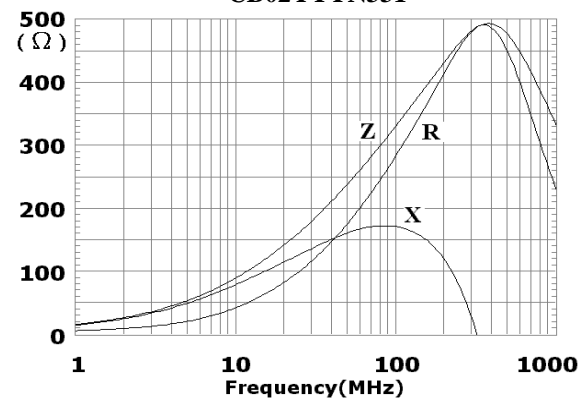

CB02YTYN481

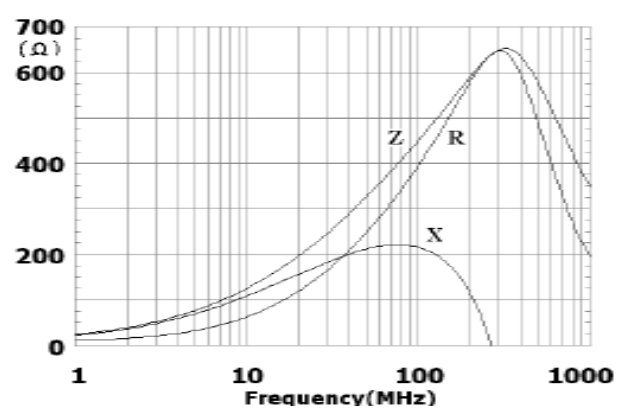

CB02YTYN601

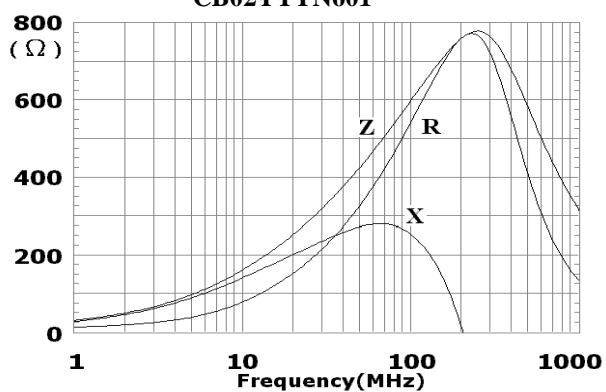

CB02YTYN102

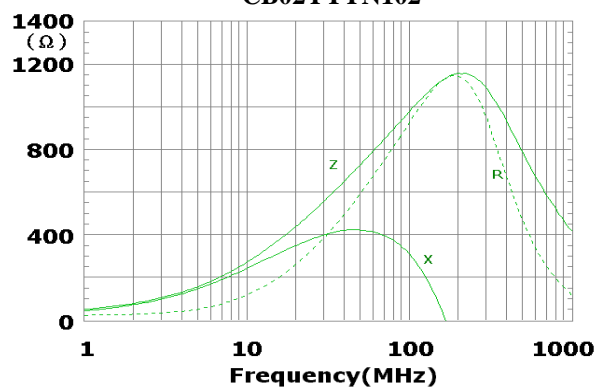

CB02YTYN152

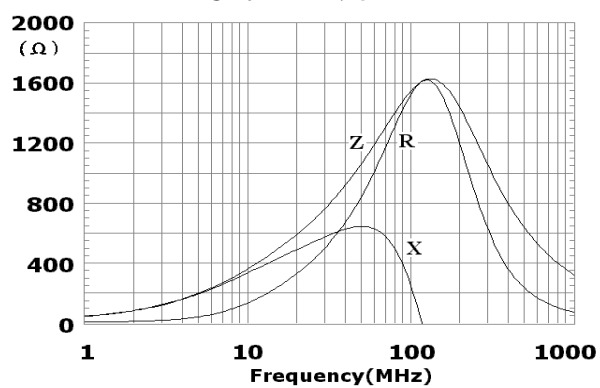

■ Characteristics (Impedance vs. Frequency) - - CB03YTYN

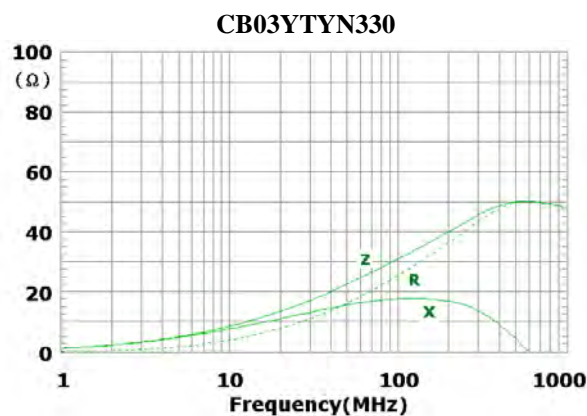
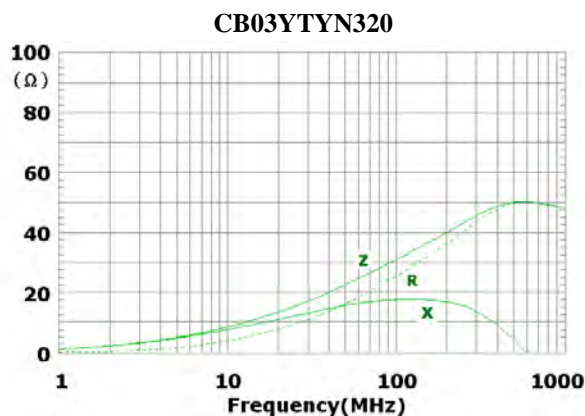
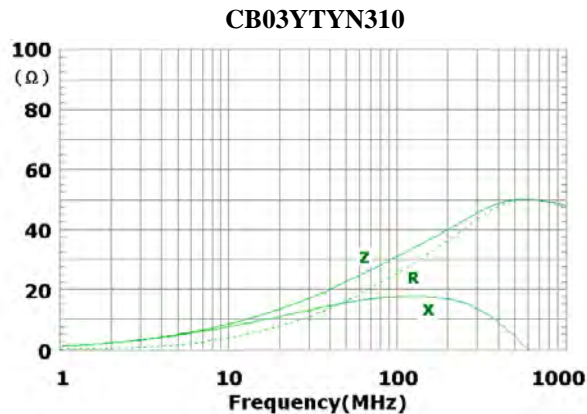
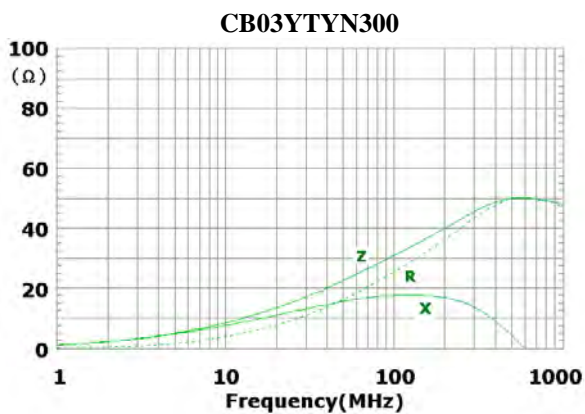
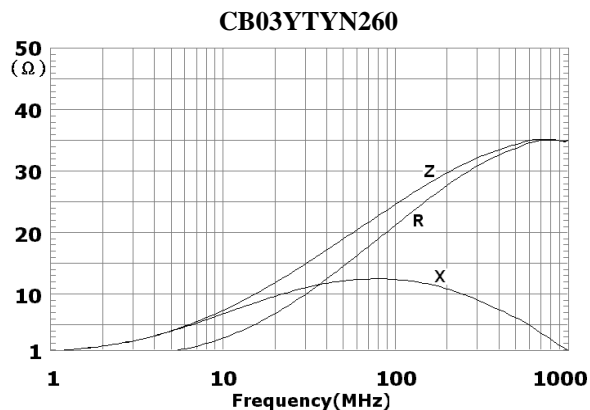
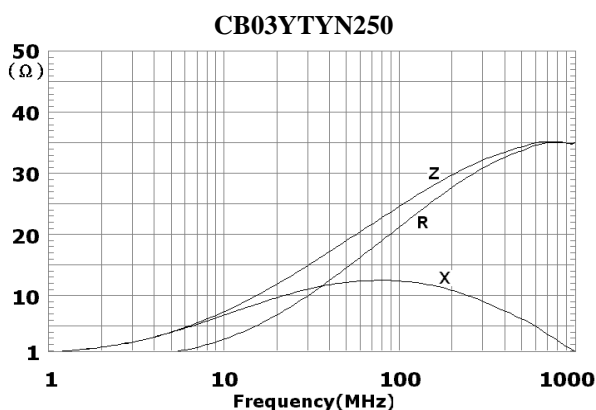
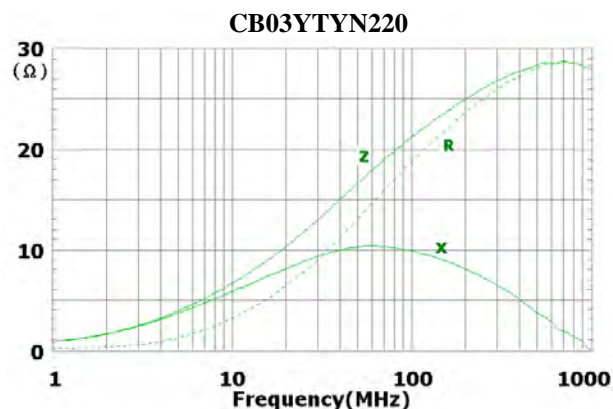
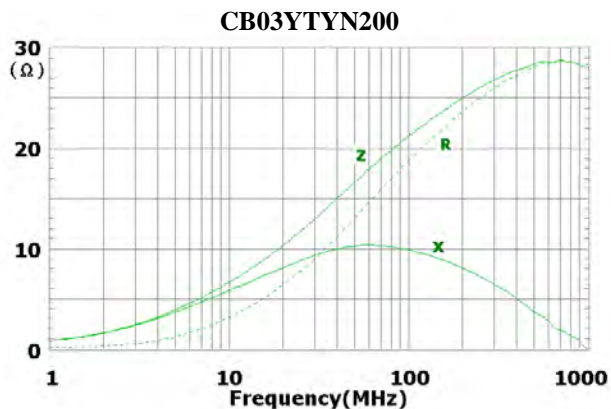

CB03YTYN400

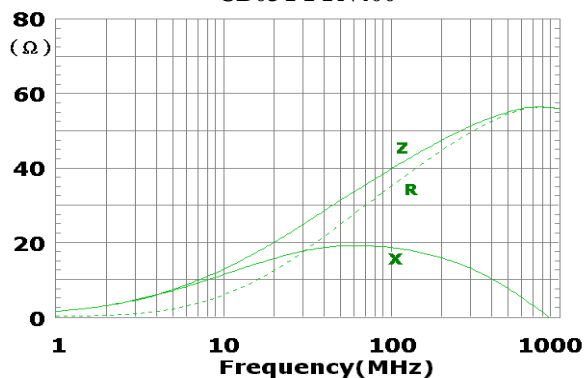

CB03YTYN470

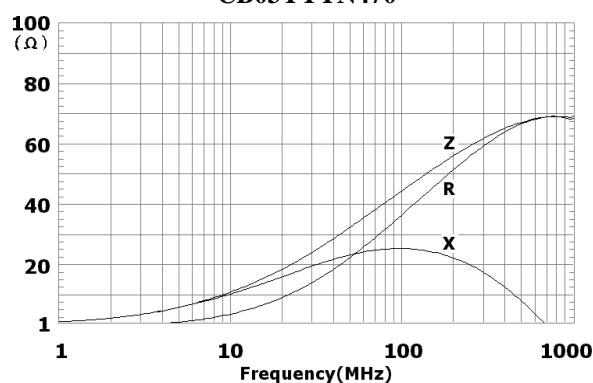

CB03YTYN600

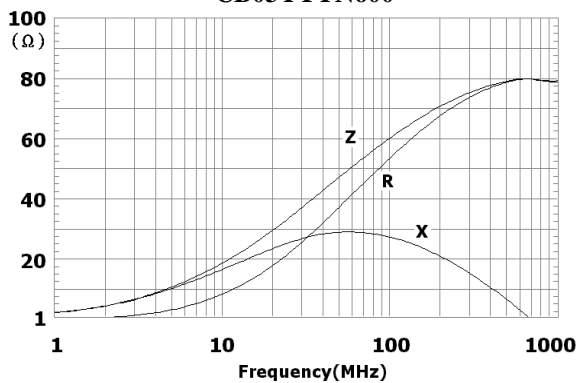

CB03YTYN680

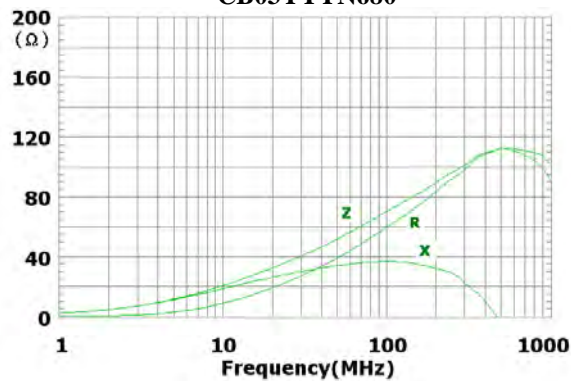

CB03YTYN700

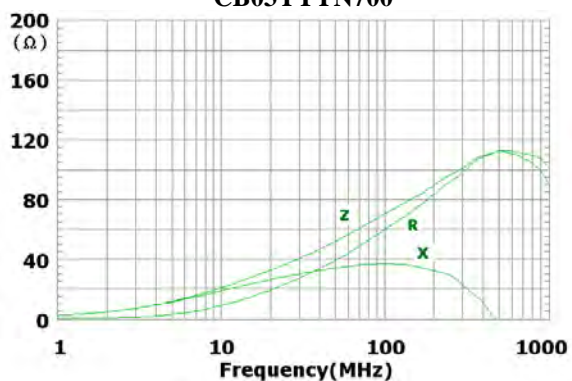

CB03YTYN750

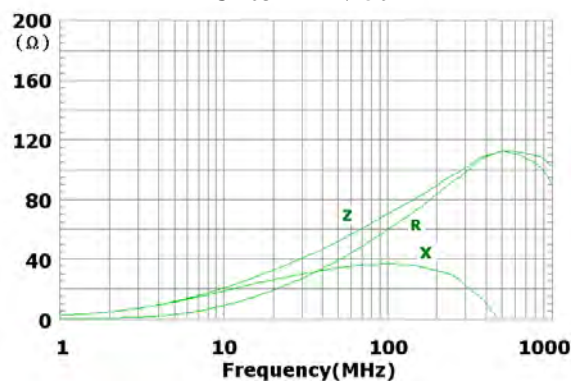

CB03YTYN800

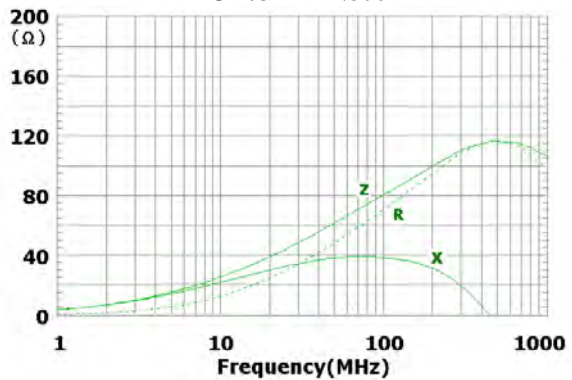

CB03YTYN900

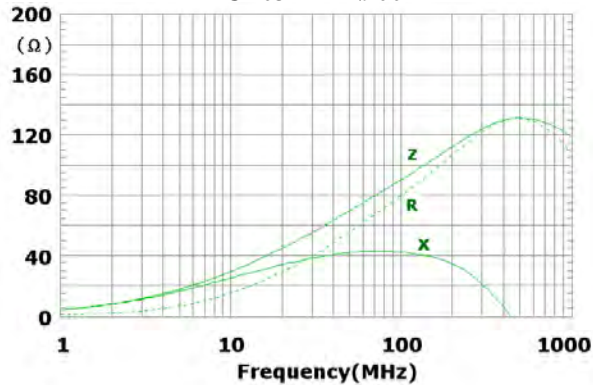

CB03YTYN101

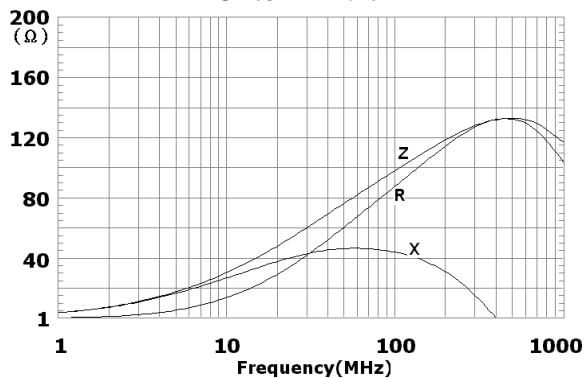

CB03YTYN121

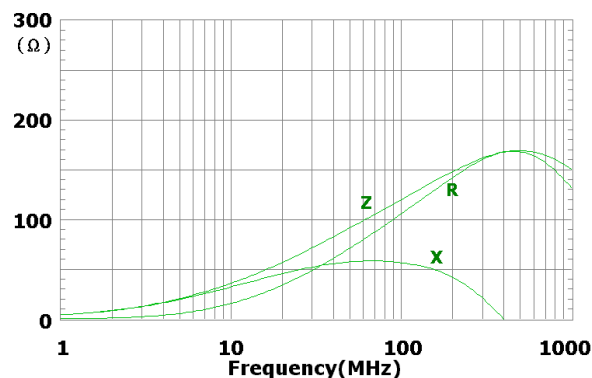

CB03YTYN151

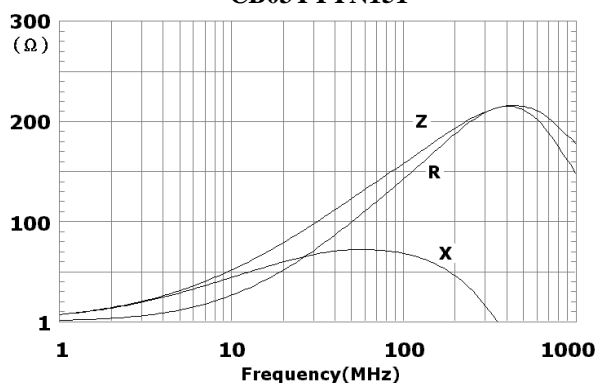

CB03YTYN181

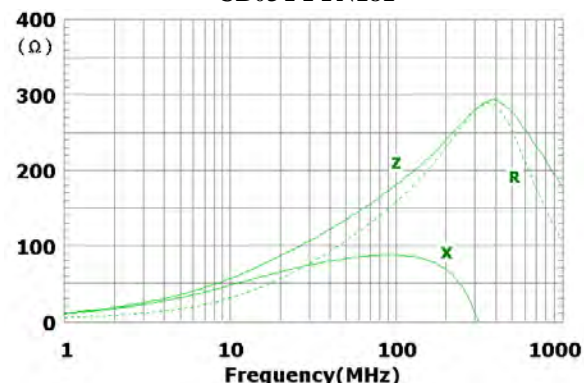

CB03YTYN201

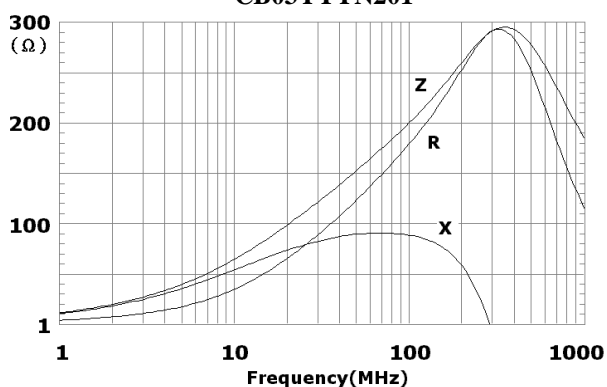

CB03YTYN221

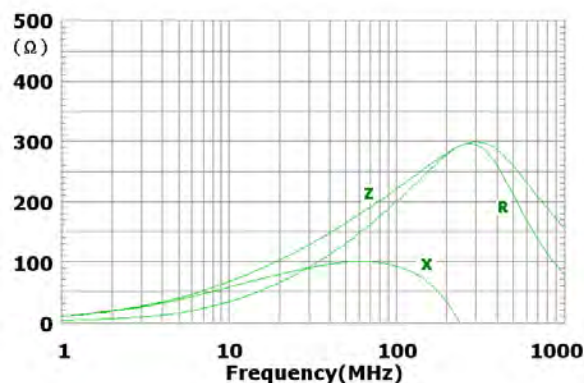

CB03YTYN241

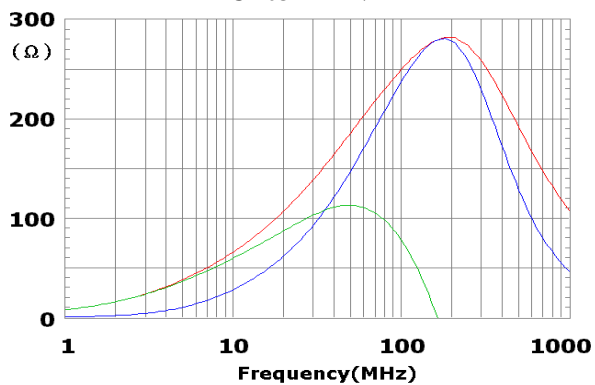

CB03YTYN301

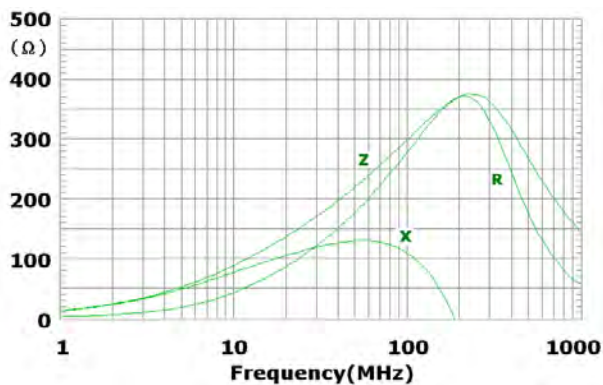

CB03YTYN331

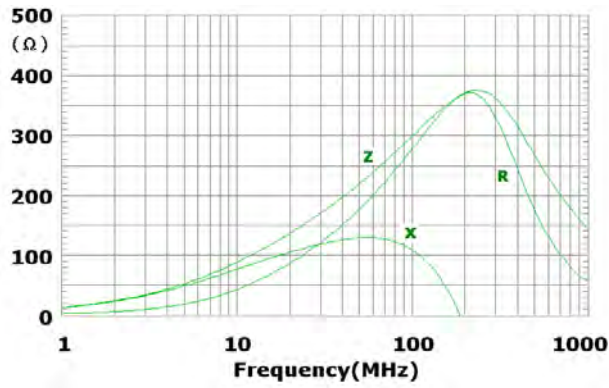

CB03YTYN401

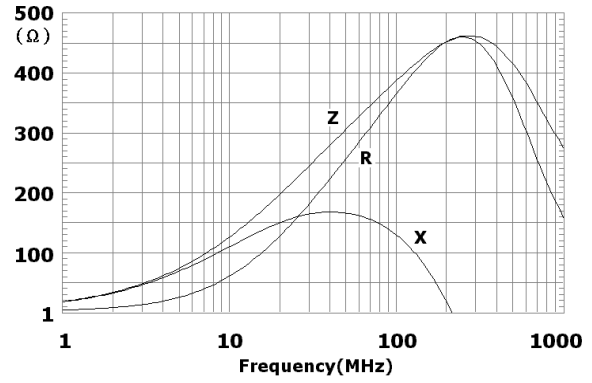

CB03YTYN421

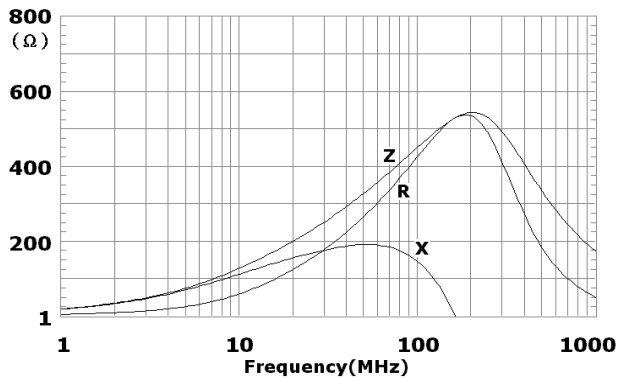

CB03YTYN451

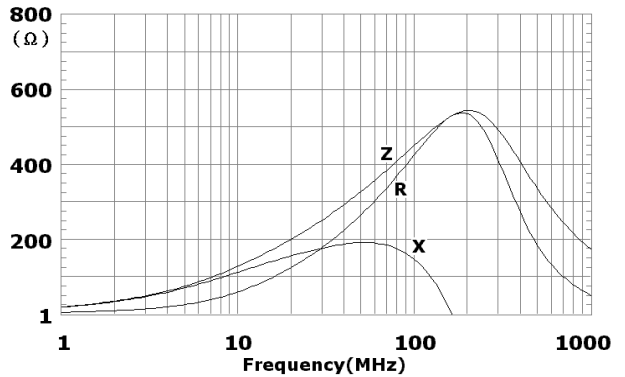

CB03YTYN471

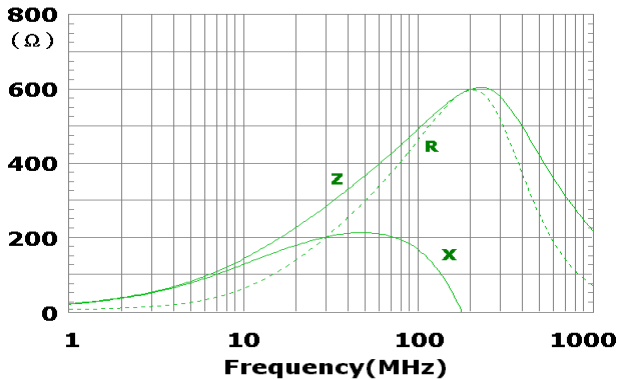

CB03YTYN501

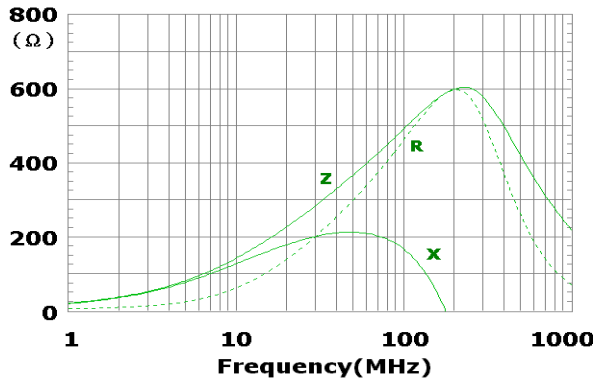

CB03YTYN601

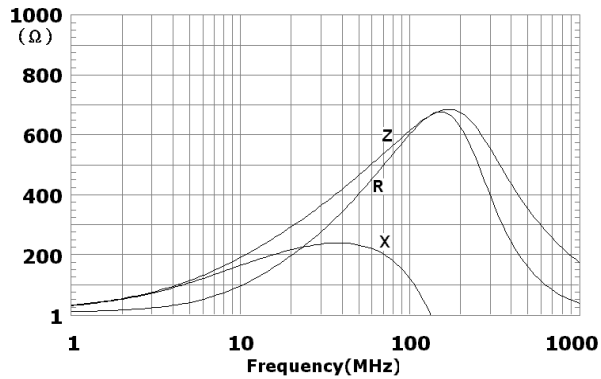

CB03YTYN751

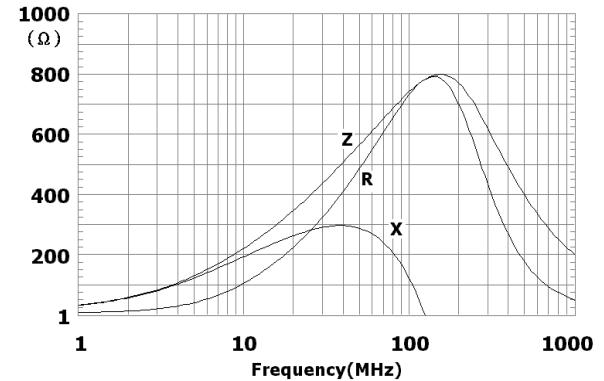

CB03YTYN801

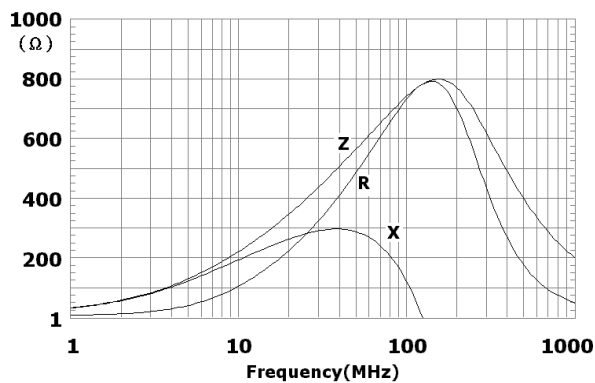

CB03YTYN102

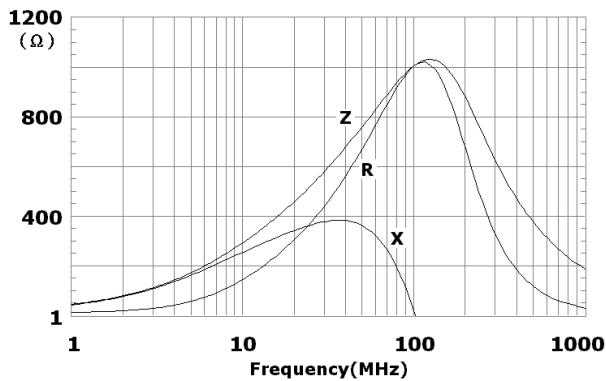

CB03YTYN122

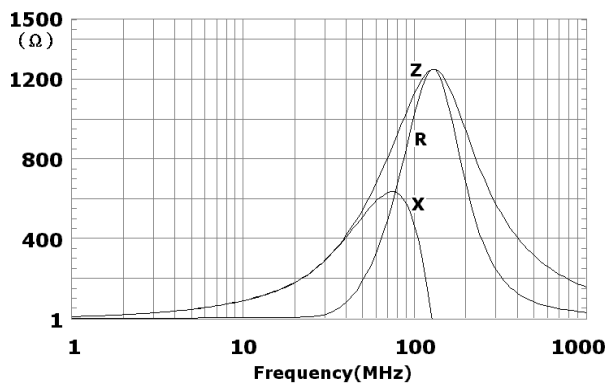

CB03YTYN152

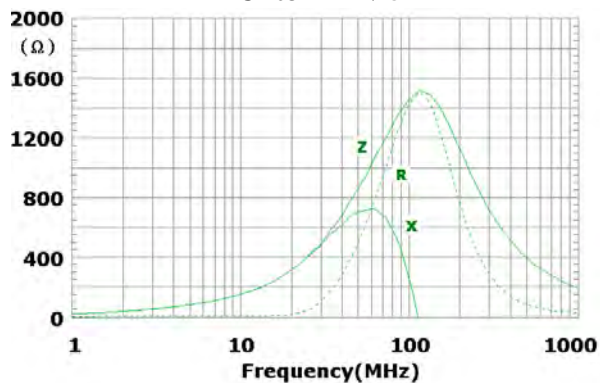

CB03YTYN202

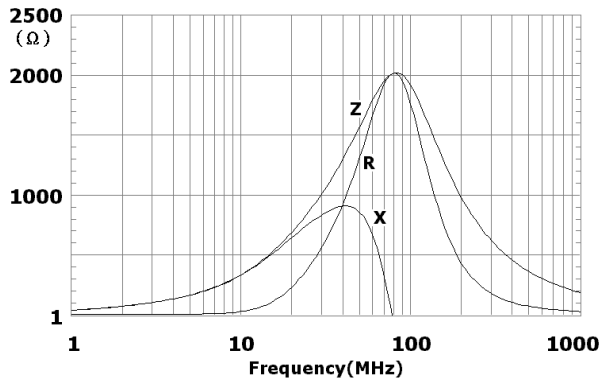

CB03YTYN222

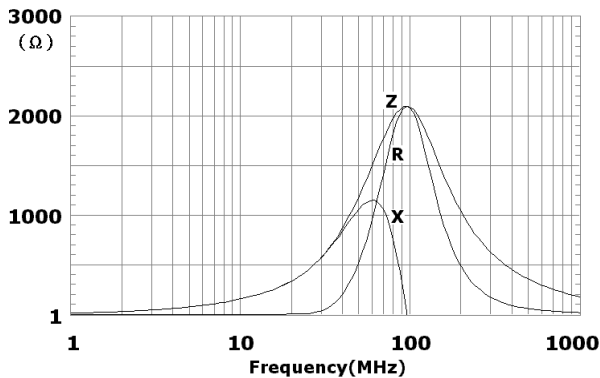

CB03YTYN252

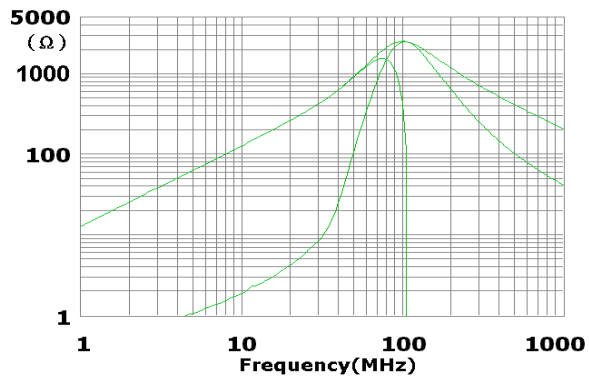

CB03YTYN272

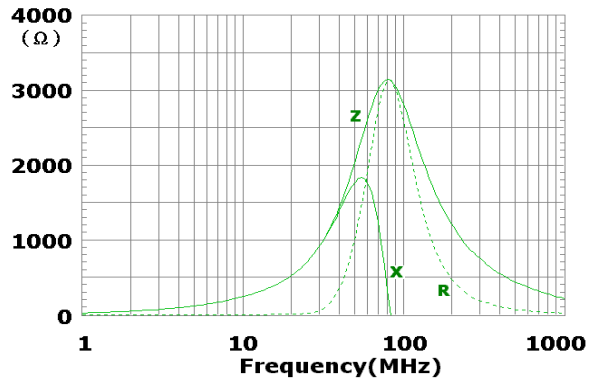

Characteristics (Impedance vs. Frequency) - - CB05YTYN

CB05YTYN260

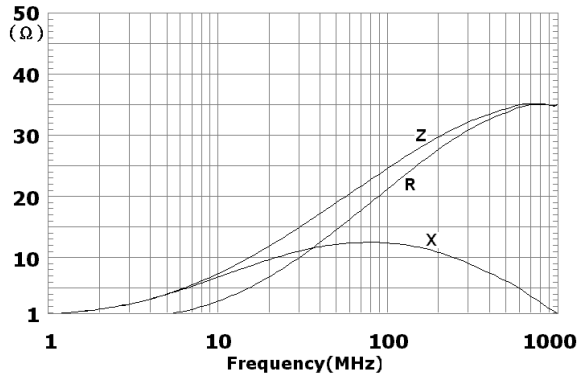

CB05YTYN600

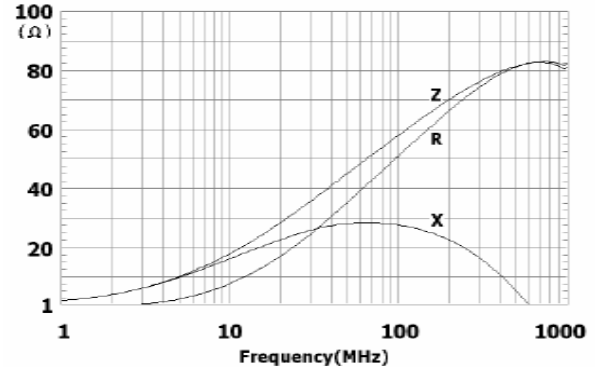

CB05YTYN700

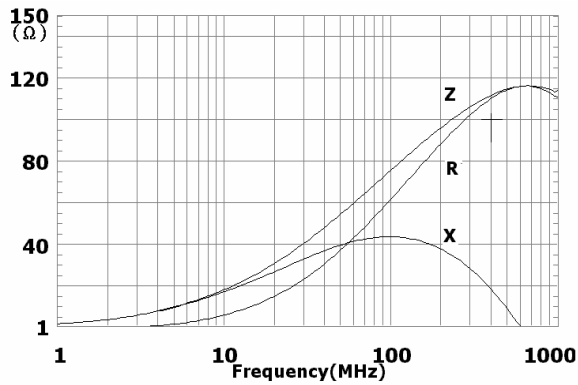

CB05YTYN750

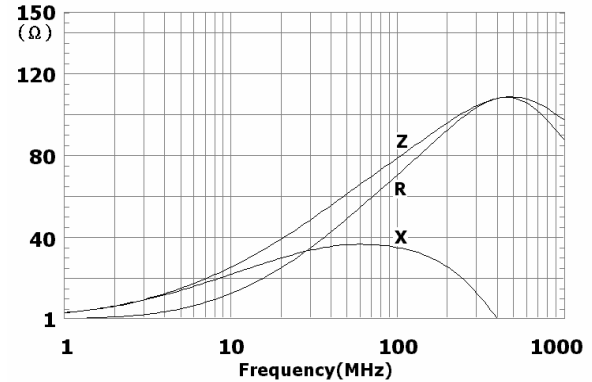

CB05YTYN800

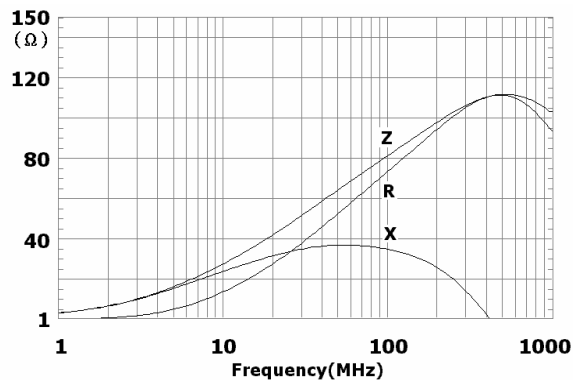

CB05YTYN900

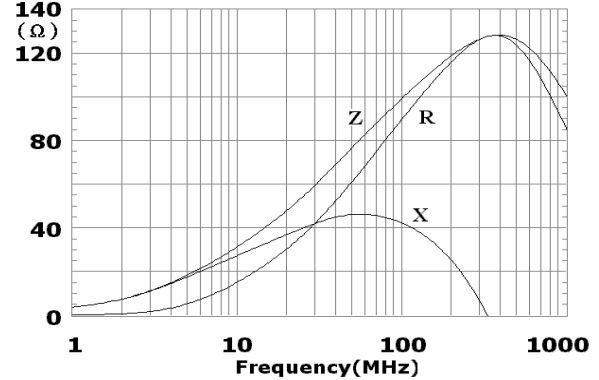

CB05YTYN101

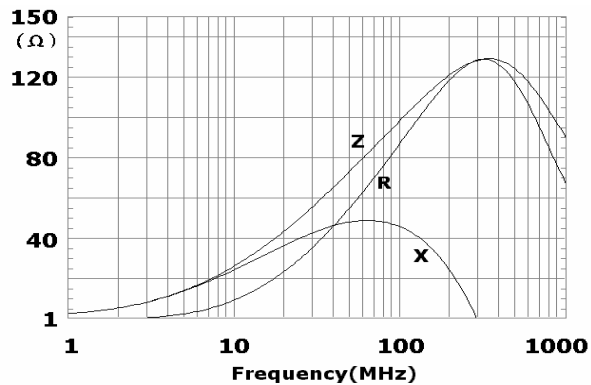

CB05YTYN121

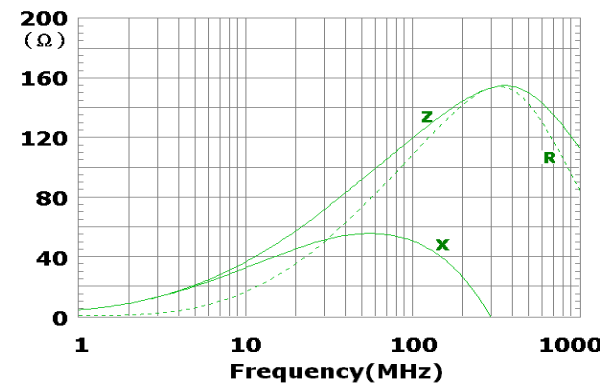

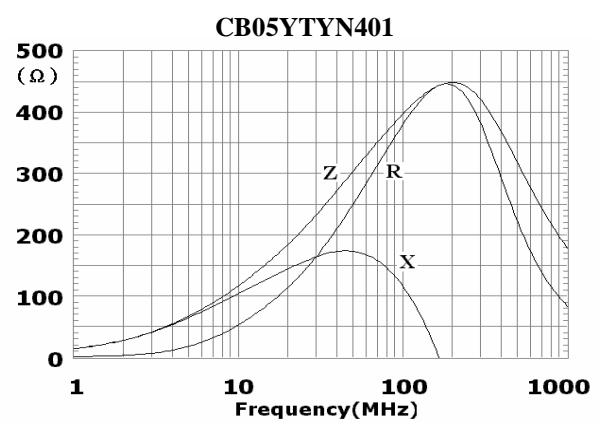
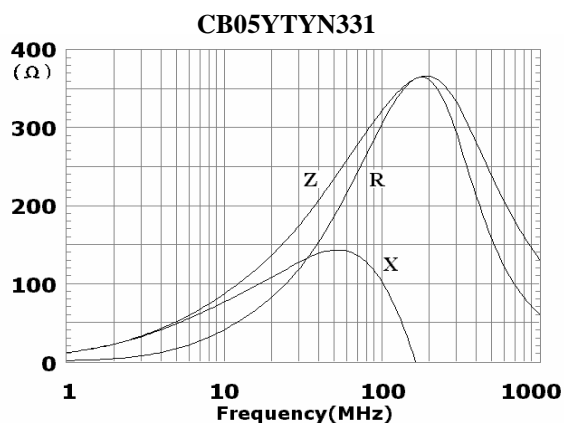
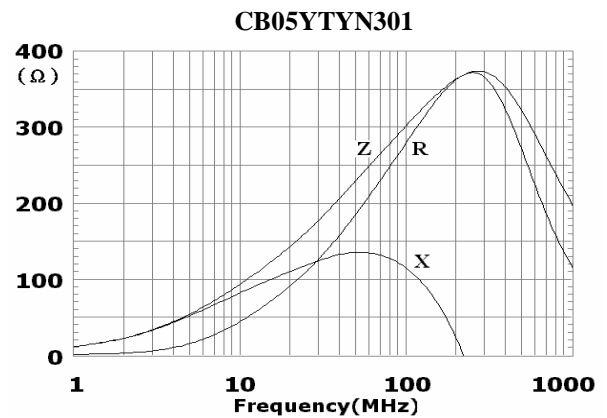
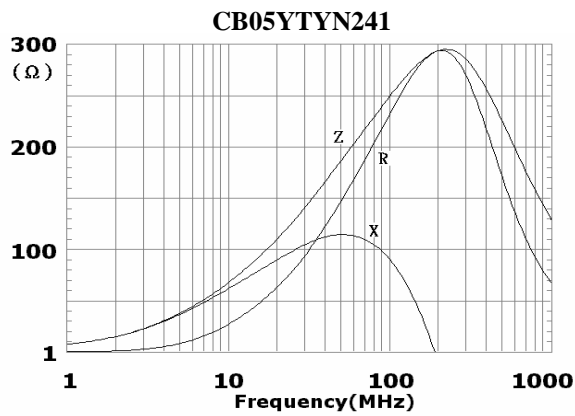
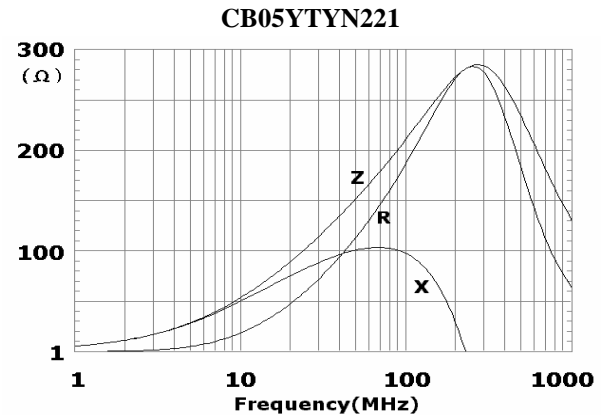
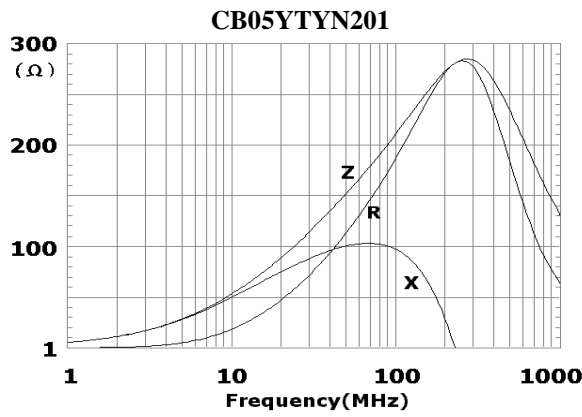
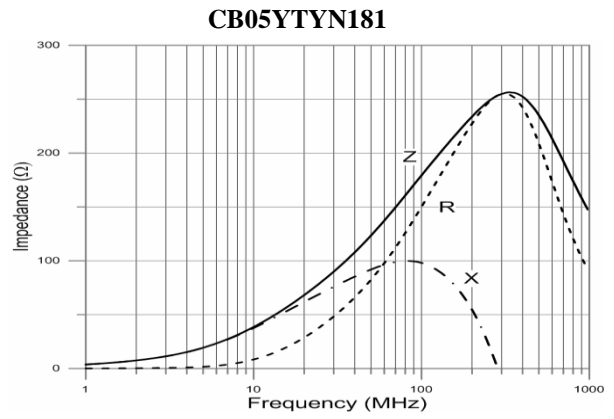
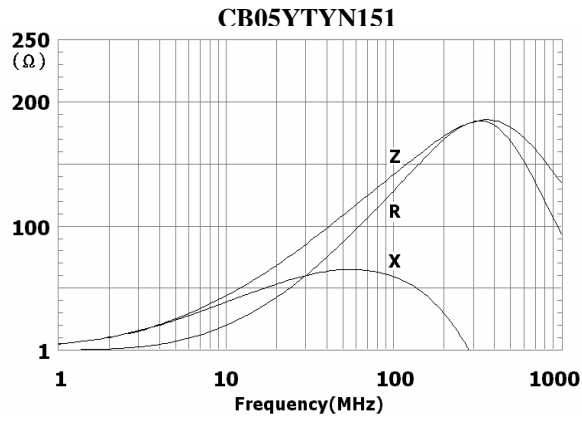

CB05YTYN471

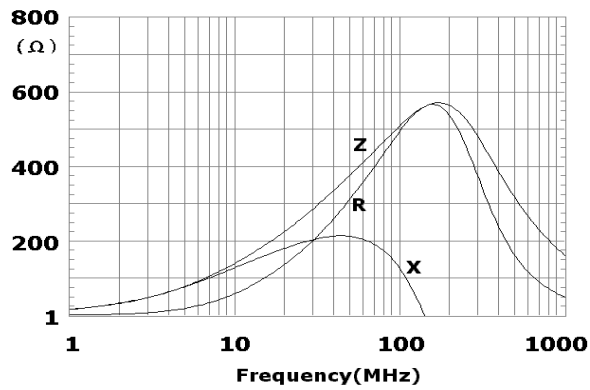

CB05YTYN501

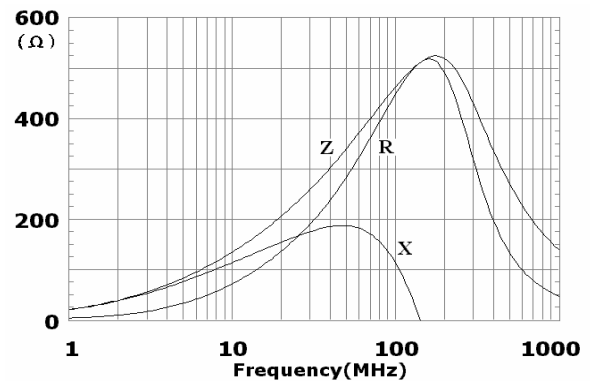

CB05YTYN601

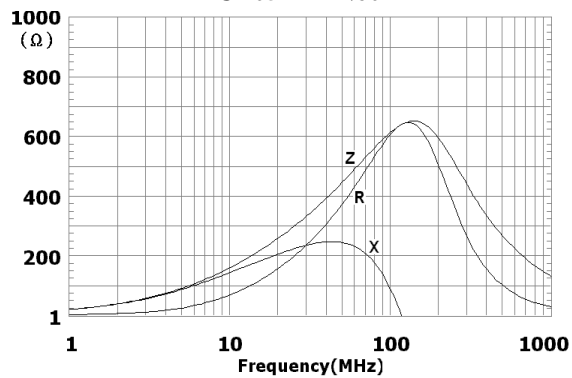

CB05YTYN681

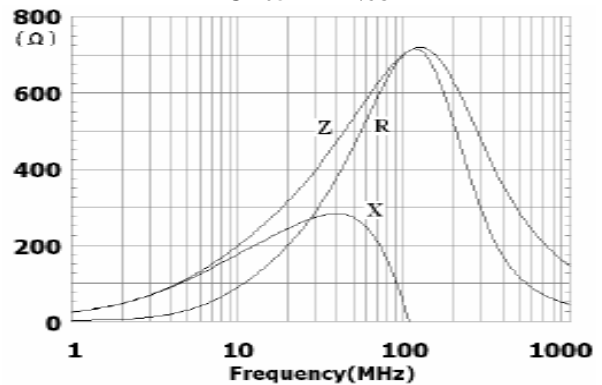

CB05YTYN751

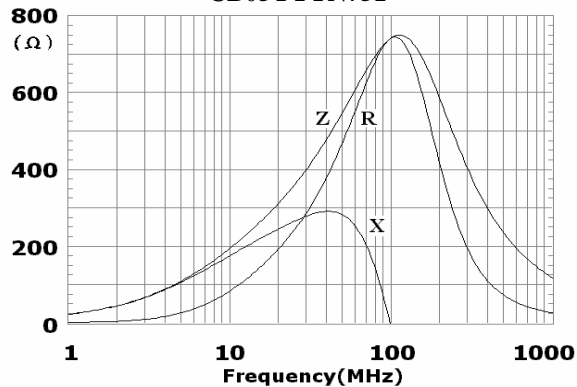

CB05YTYN102

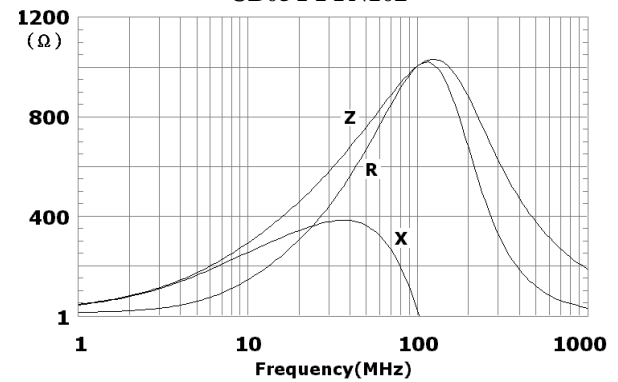

CB05YTYN122

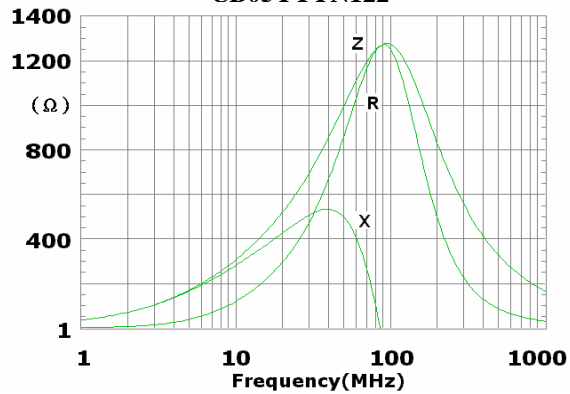

CB05YTYN152

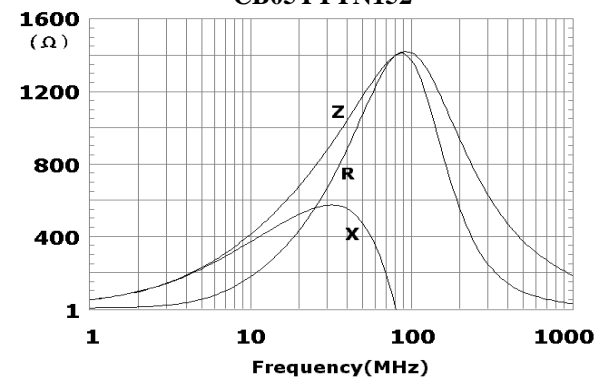

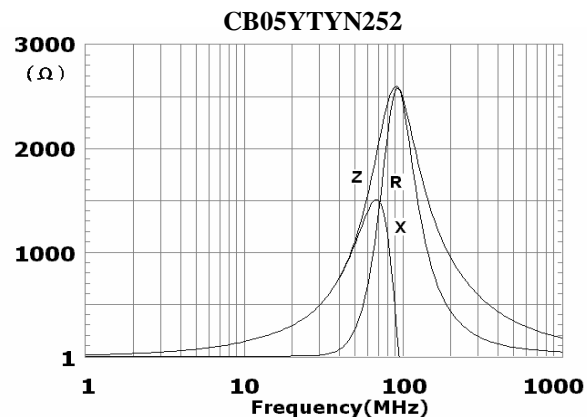
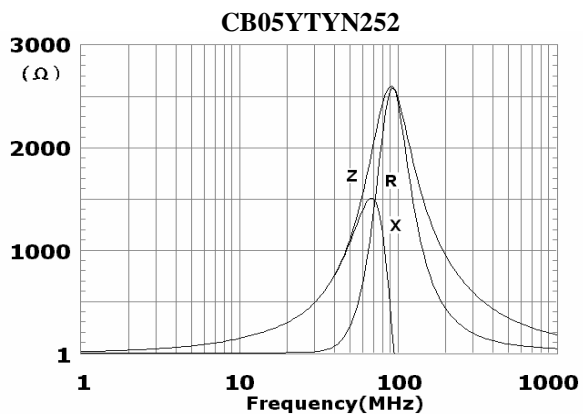
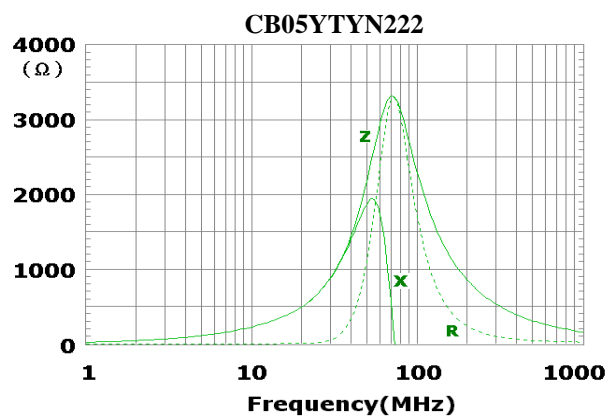
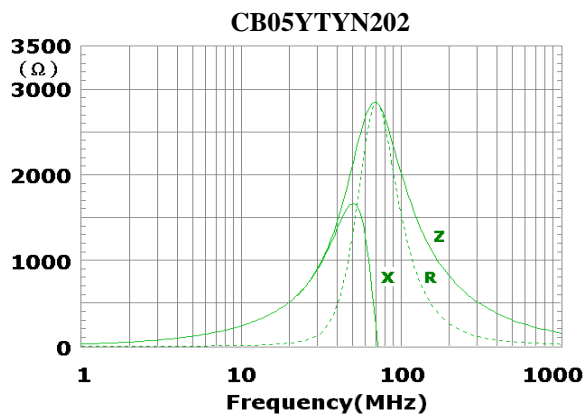

■ Characteristics (Impedance vs. Frequency) - - CB04YTYN

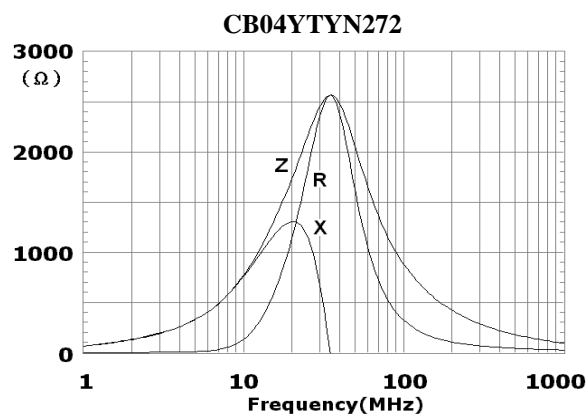
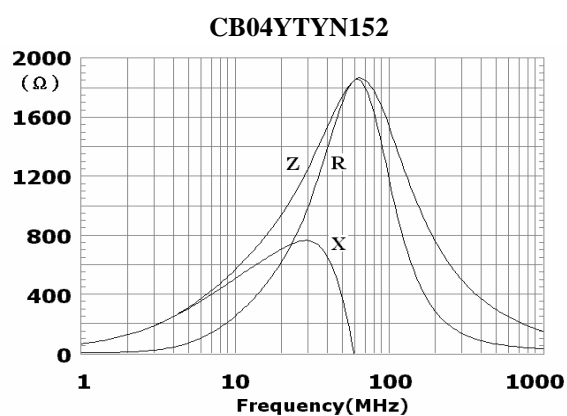
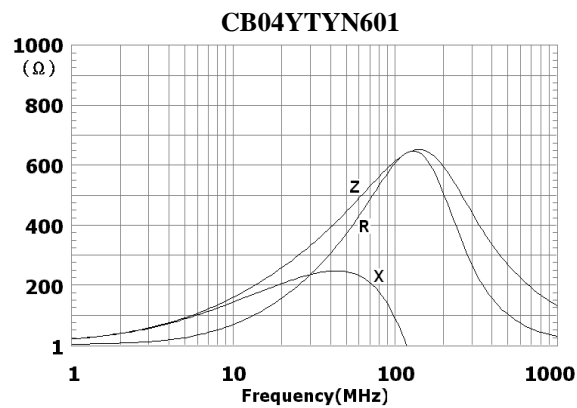
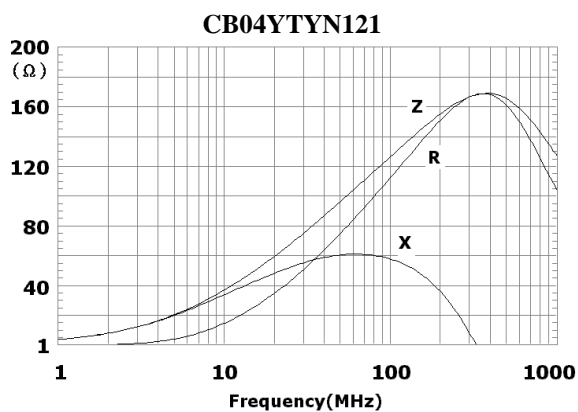

■ Characteristics (Impedance vs. Frequency) - - CB010YTYN

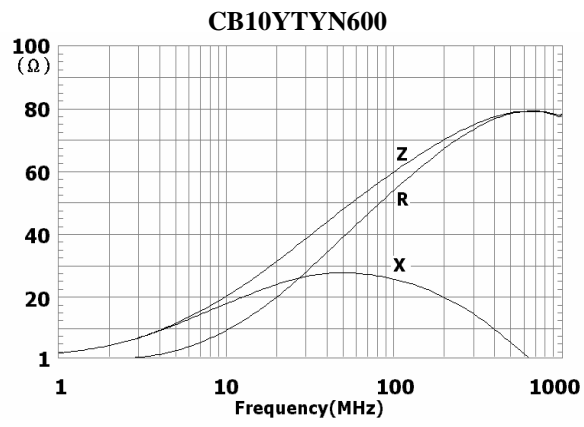

■ Characteristics (Impedance vs. Frequency) - - CB03YTYH

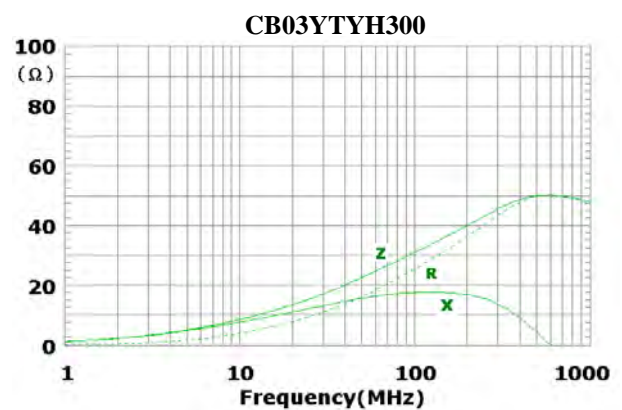
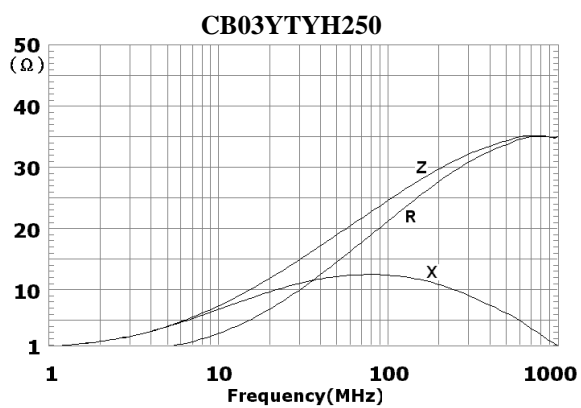
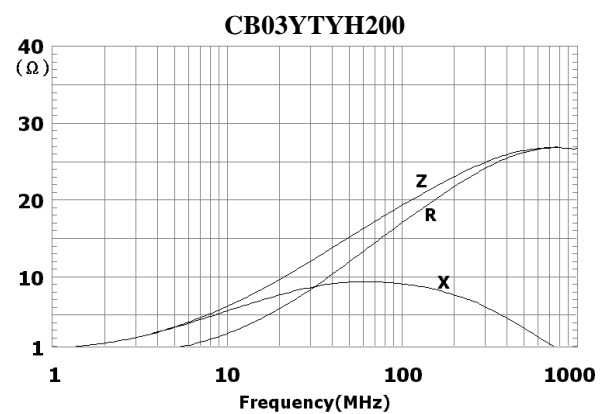
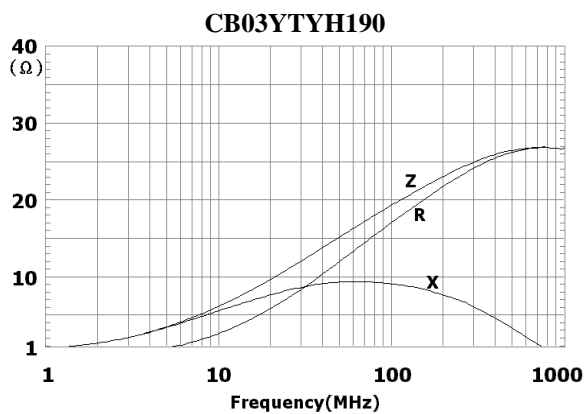
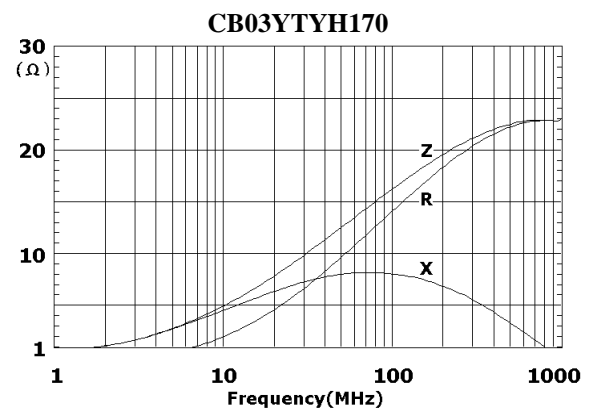
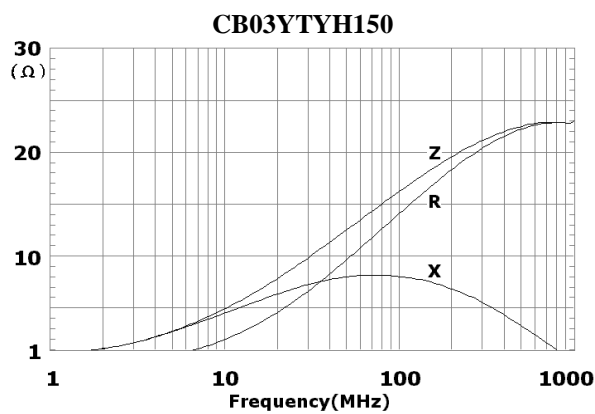
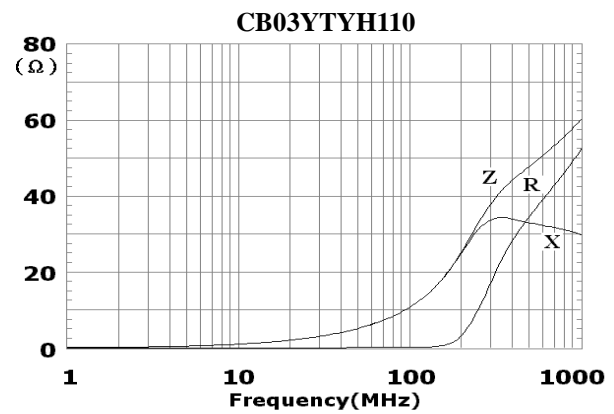
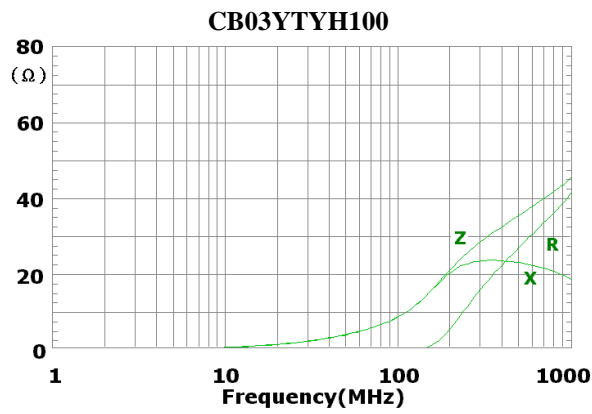

CB03YTYH680

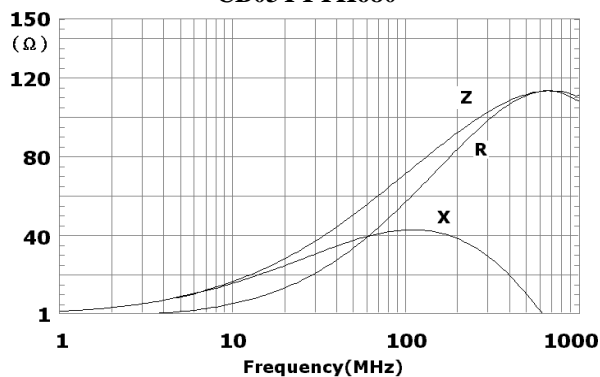

CB03YTYH700

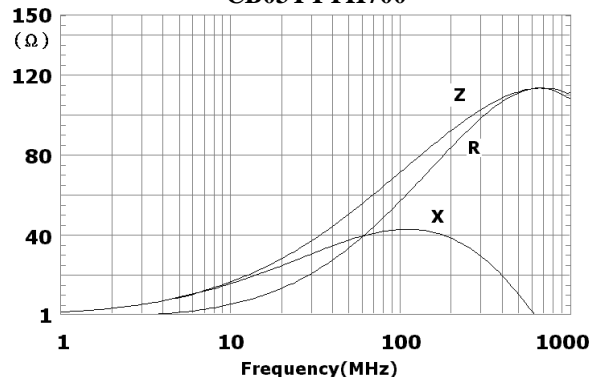

CB03YTYH750

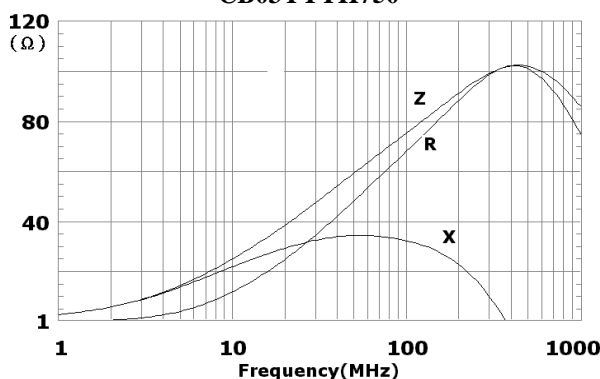

CB03YTYH800

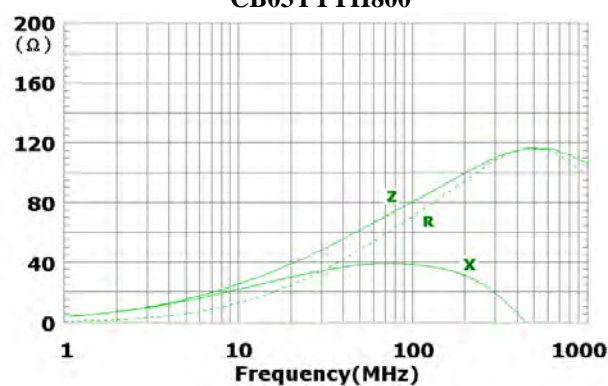

CB03YTYH101

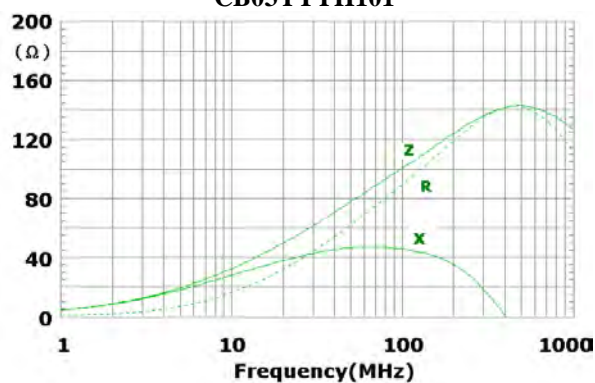

CB03YTYH121

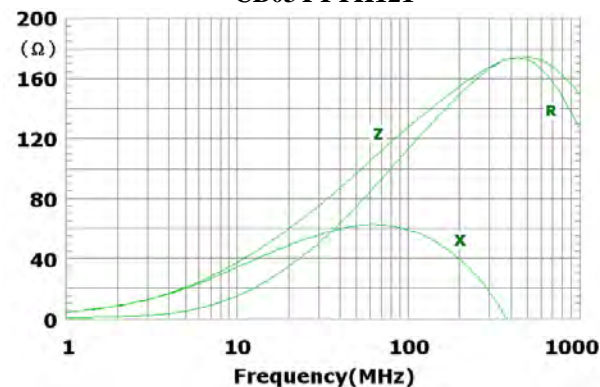

CB03YTYH151

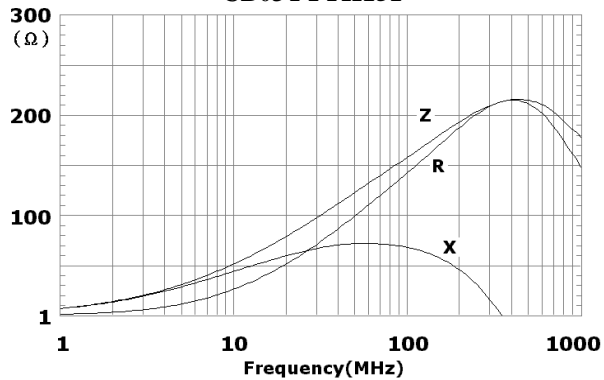

CB03YTYH181

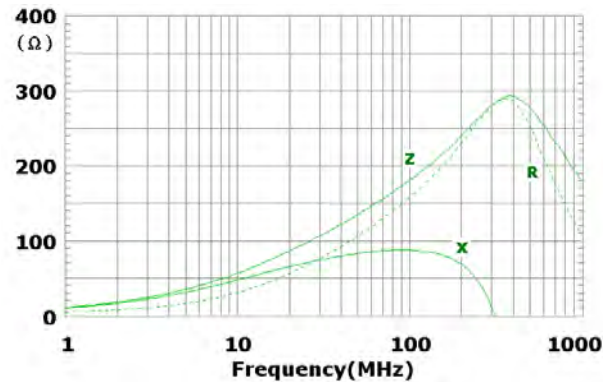

CB03YTYH201

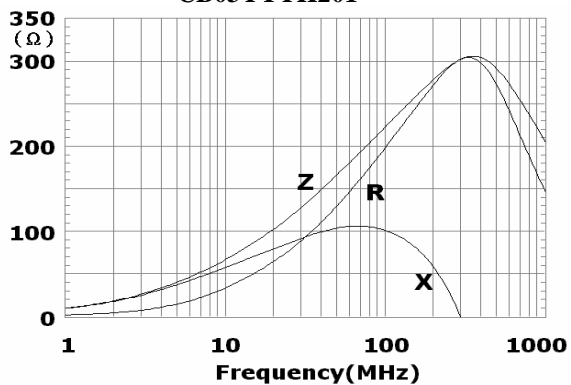

CB03YTYH221

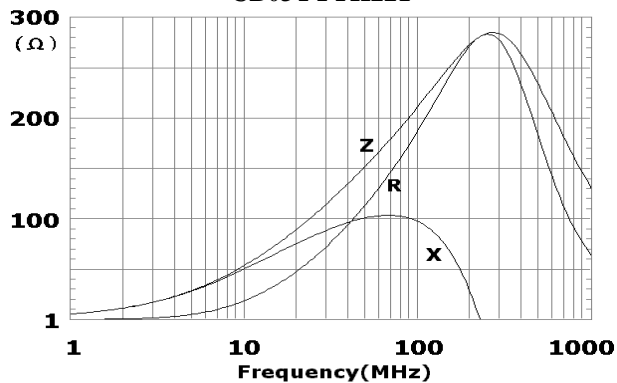

CB03YTYH241

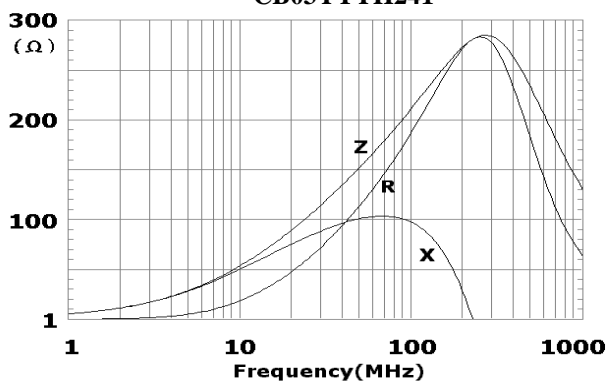

CB03YTYH301

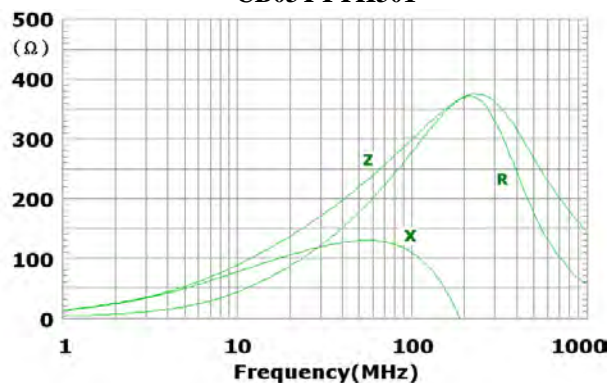

CB03YTYH331

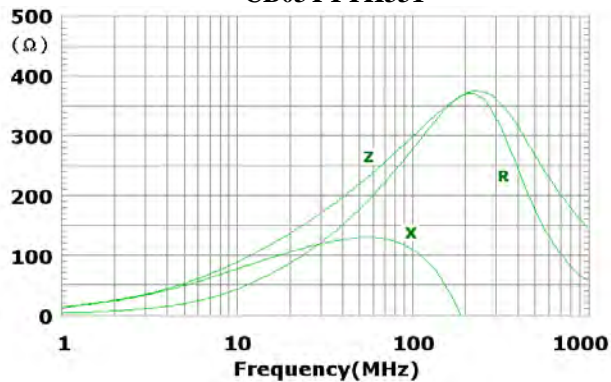

CB03YTYH401

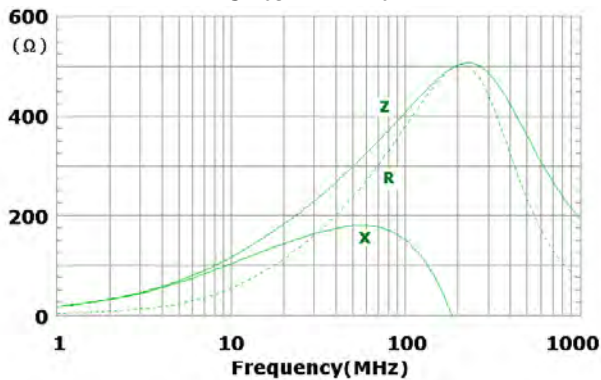

CB03YTYH451

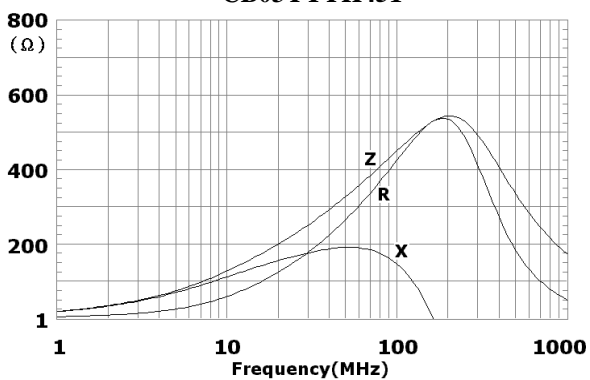

CB03YTYH471

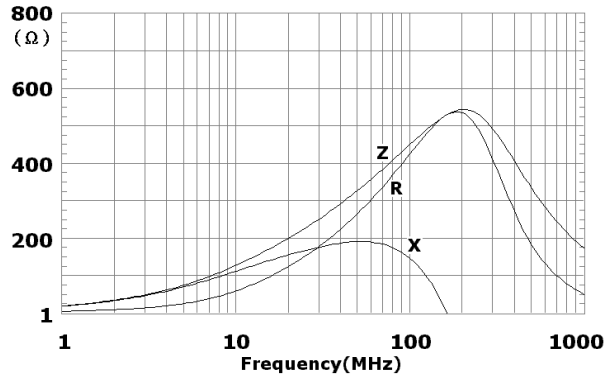

CB03YTYH601

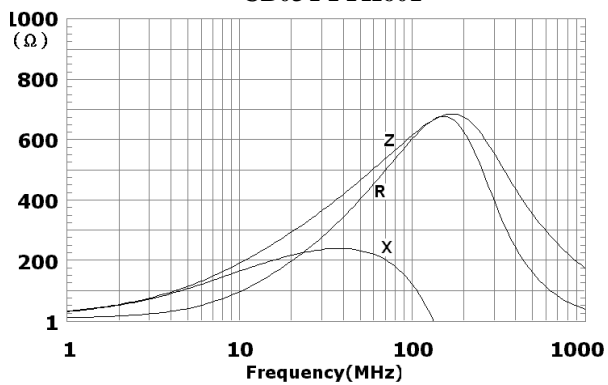

CB03YTYH701

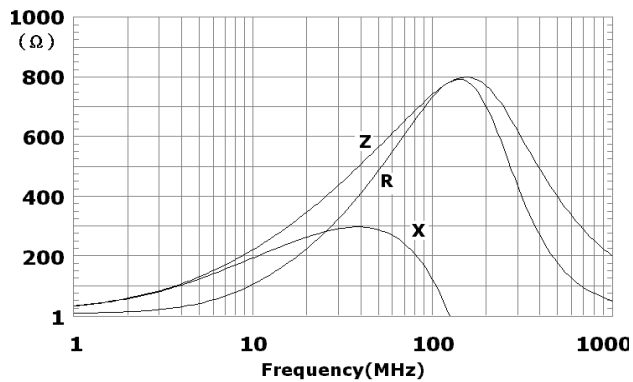

CB03YTYH102

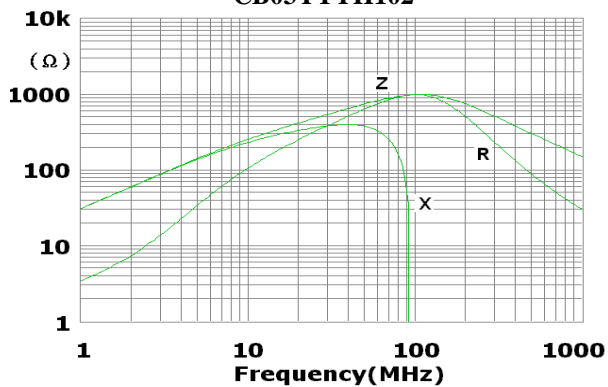

CB03YTYH152

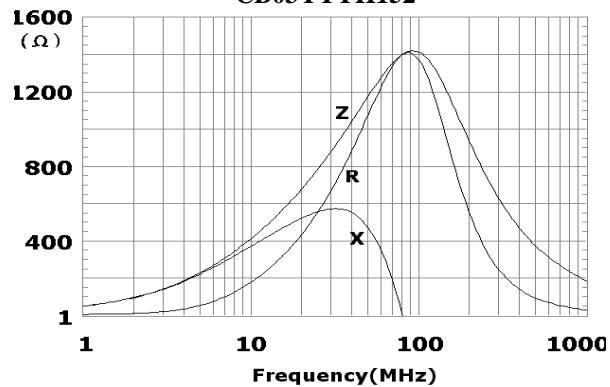

■ Characteristics (Impedance vs. Frequency) - - CB05YTYH

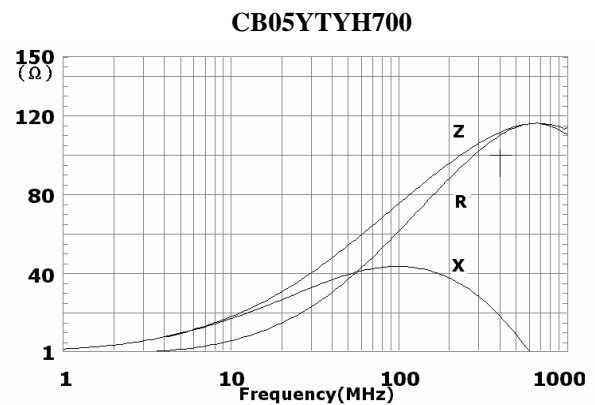
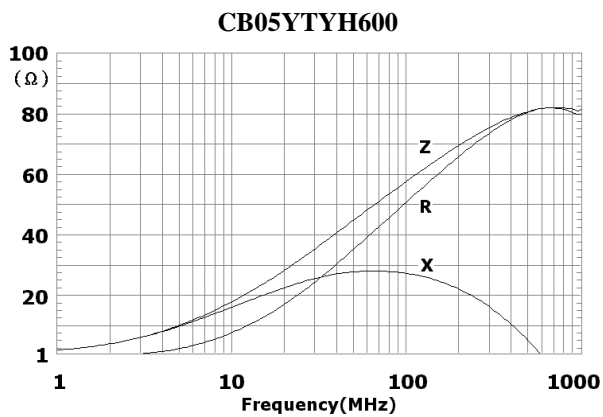
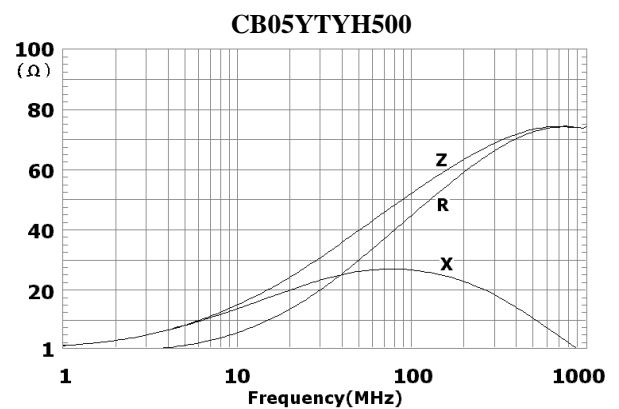
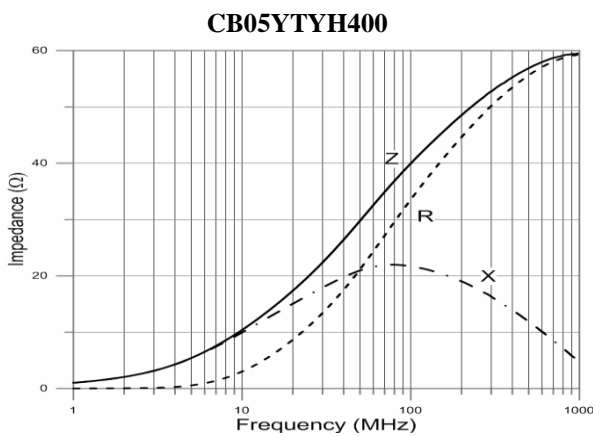
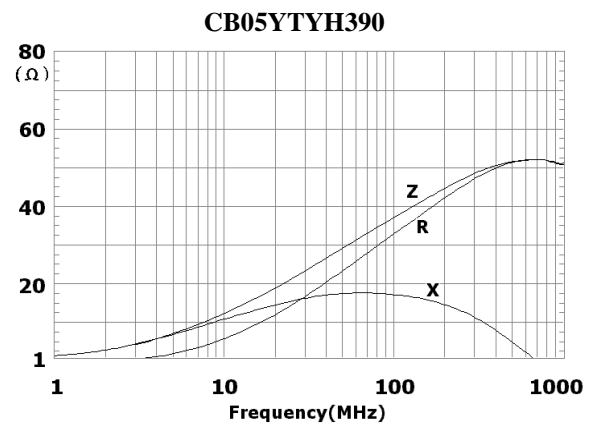
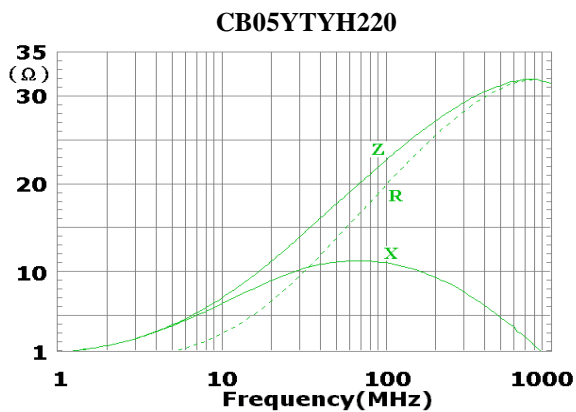
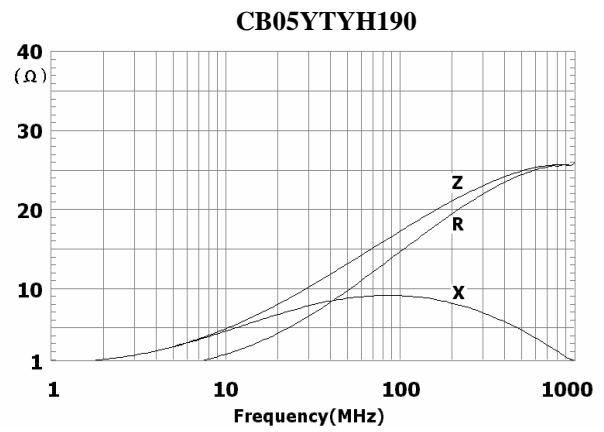
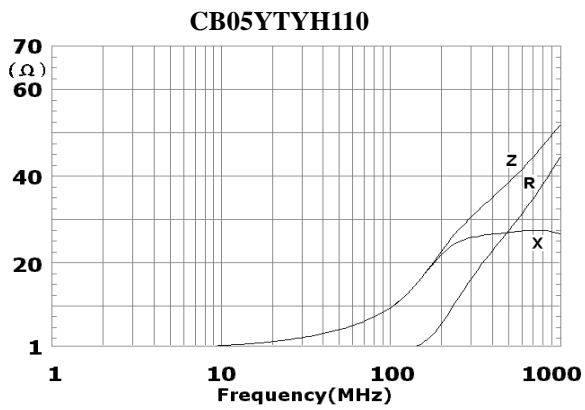

CB05YTYH750

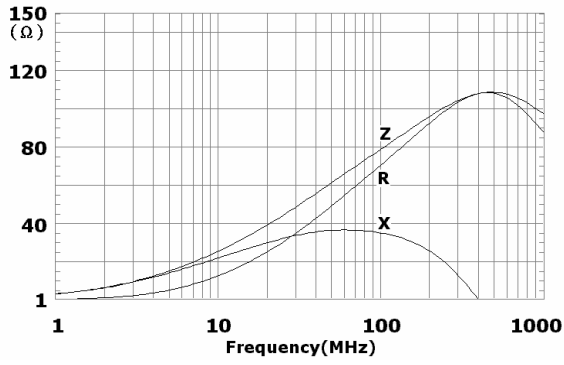

CB05YTYH800

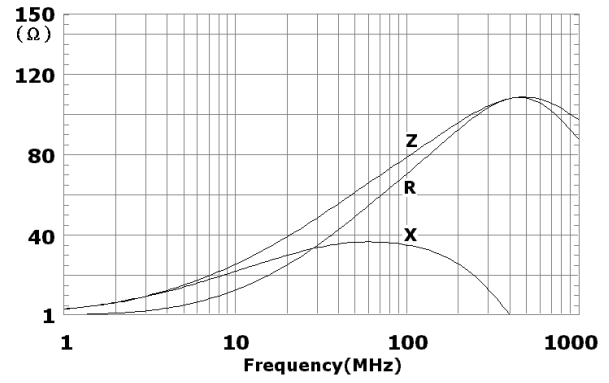

CB05YTYH900

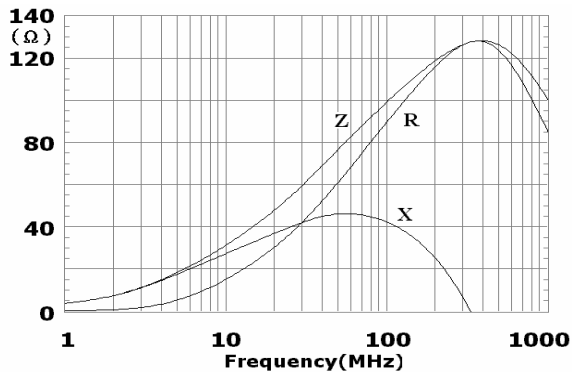

CB05YTYH101

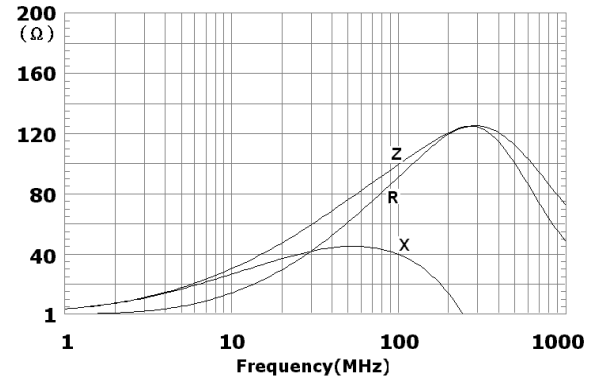

CB05YTYH121

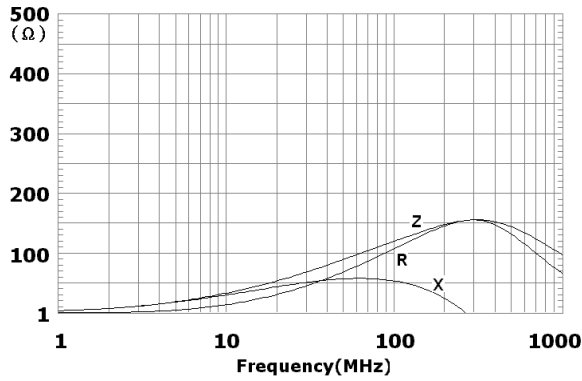

CB05YTYH151

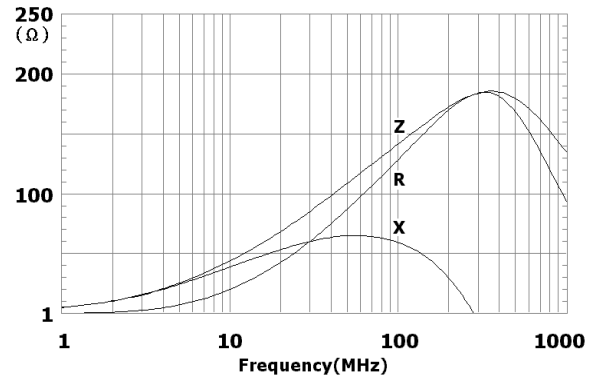

CB05YTYH181

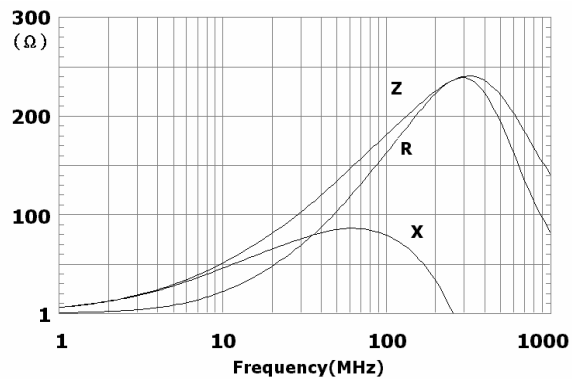

CB05YTYH201

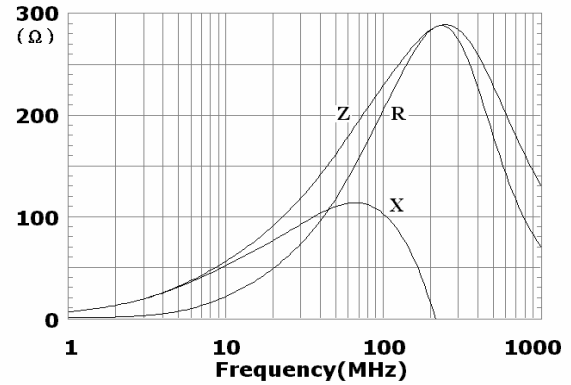

CB05YTYH221

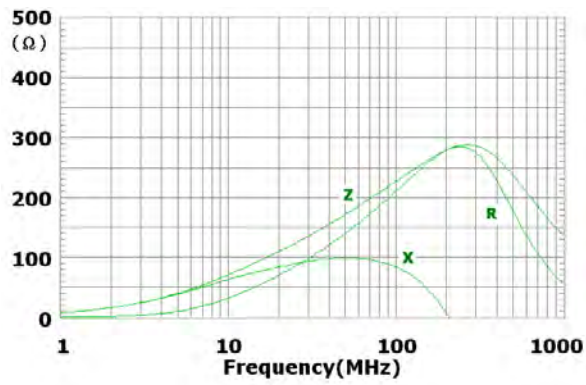

CB05YTYH301

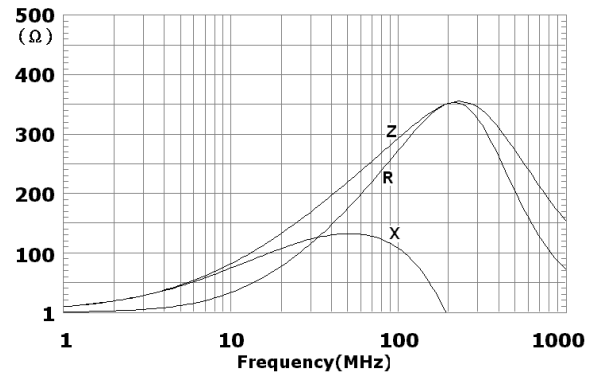

CB05YTYH331

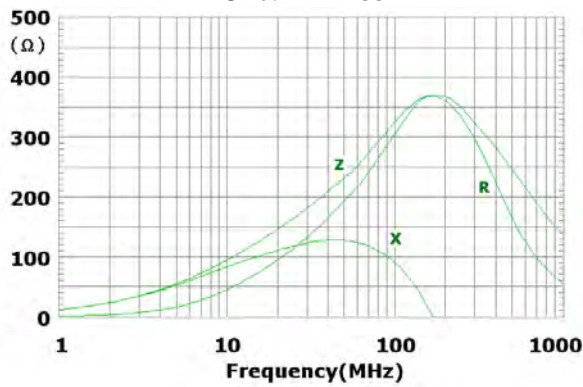

CB05YTYH401

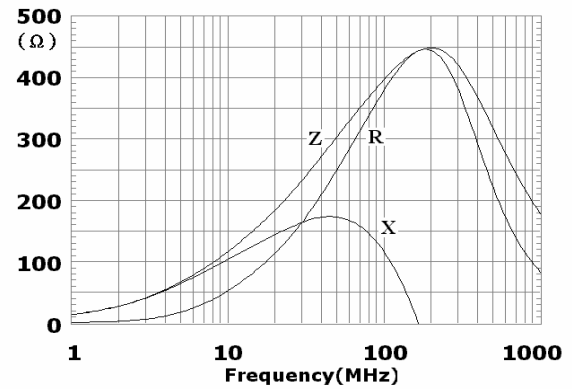

CB05YTYH471

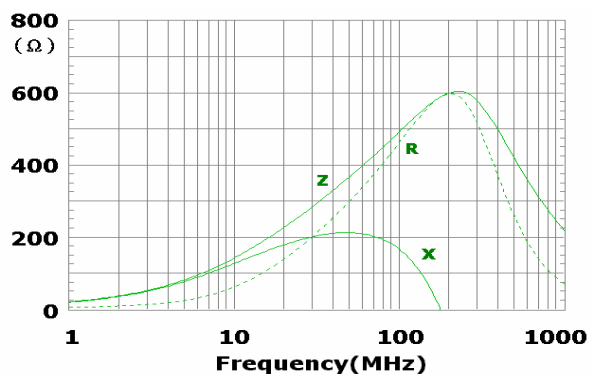

CB05YTYH501

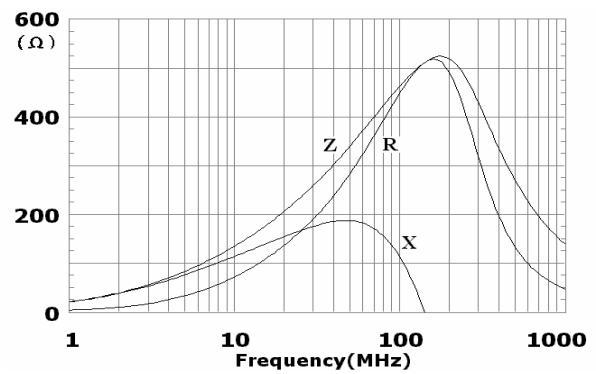

CB05YTYH601

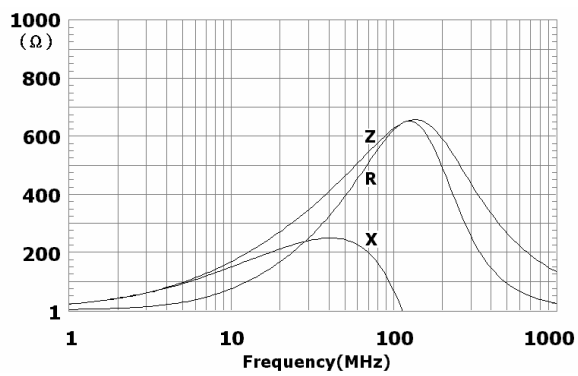

CB05YTYH751

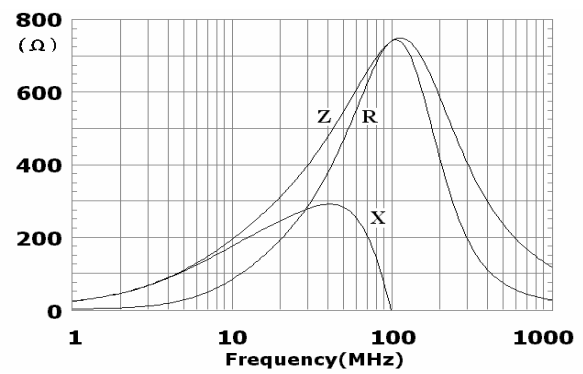

CB05YTYH102

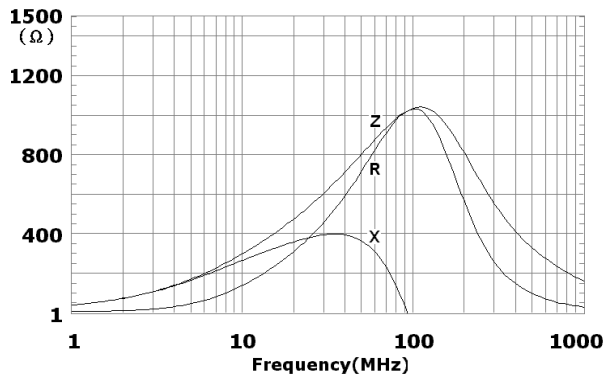

CB05YTYH152

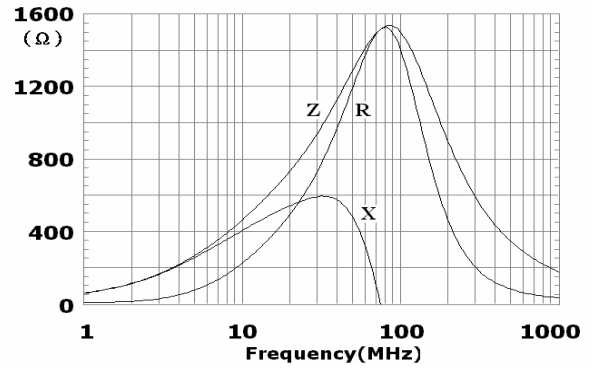

Characteristics (Impedance vs. Frequency) - - CB04YTYH

CB04YTYH260

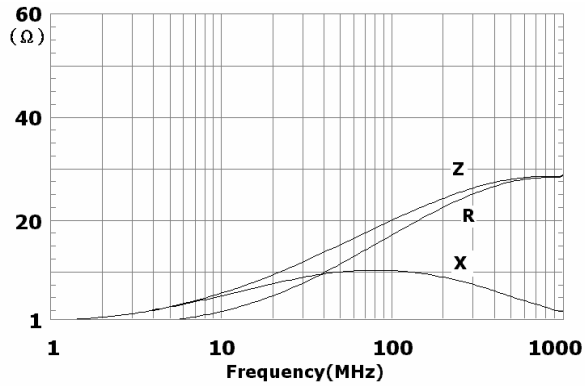

CB04YTYH300

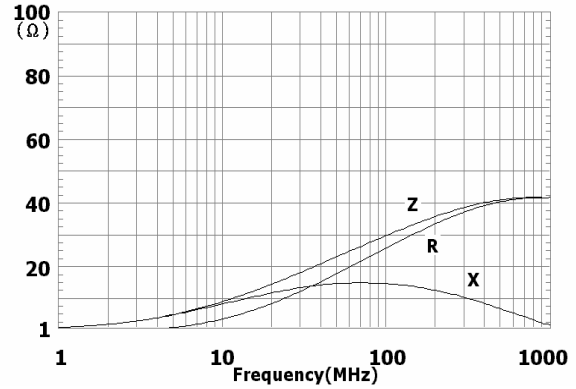

CB04YTYH310

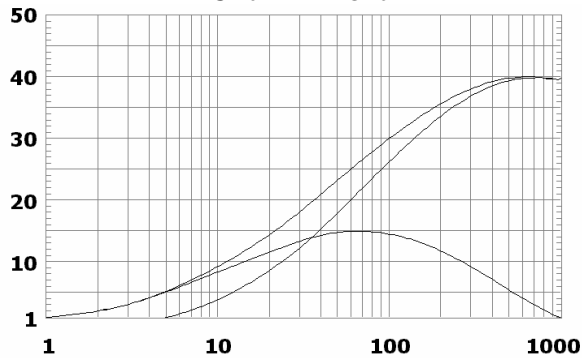

CB04YTYH320

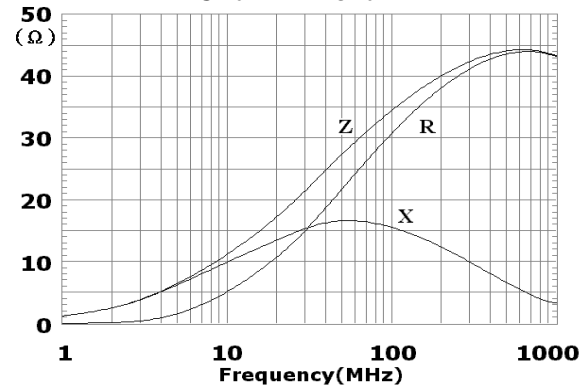

CB04YTYH400

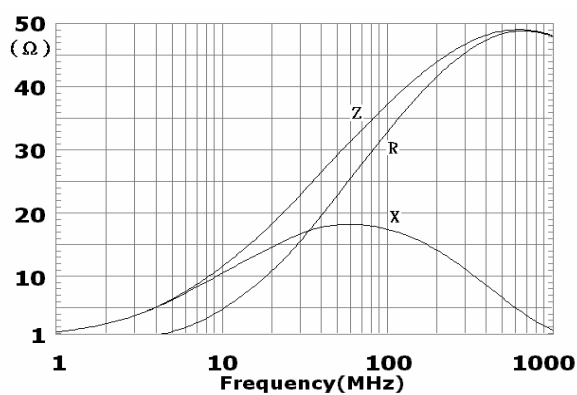

CB04YTYH420

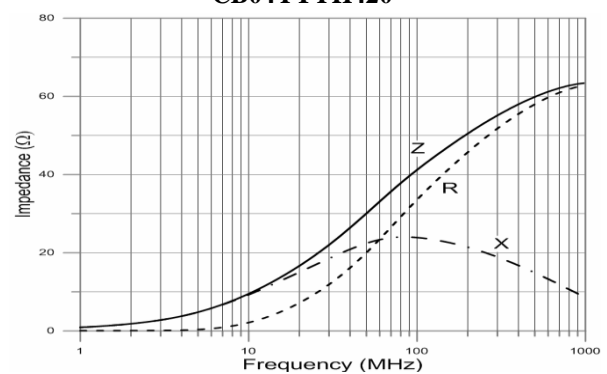

CB04YTYH480

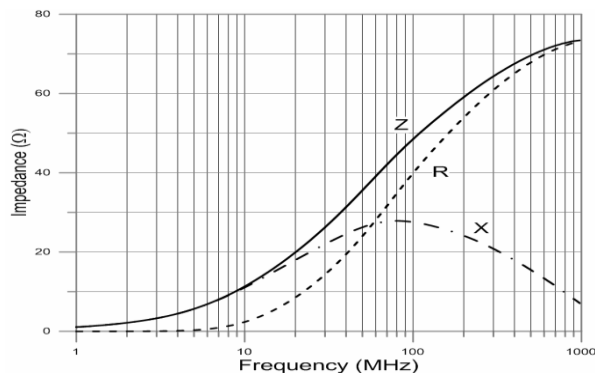

CB04YTYH500

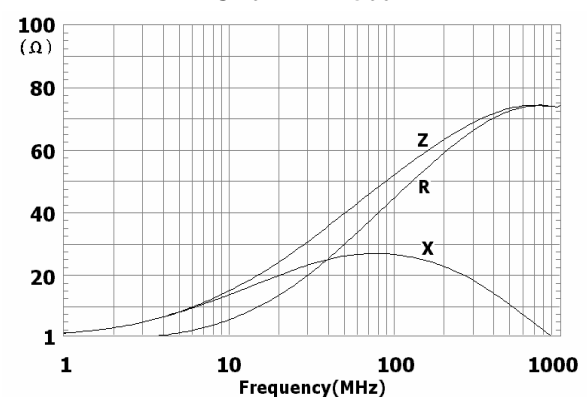

CB04YTYH520

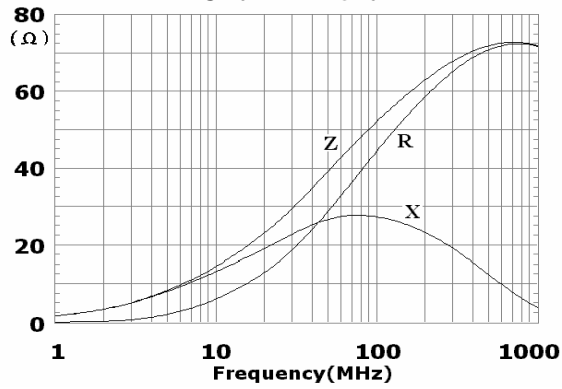

CB04YTYH600

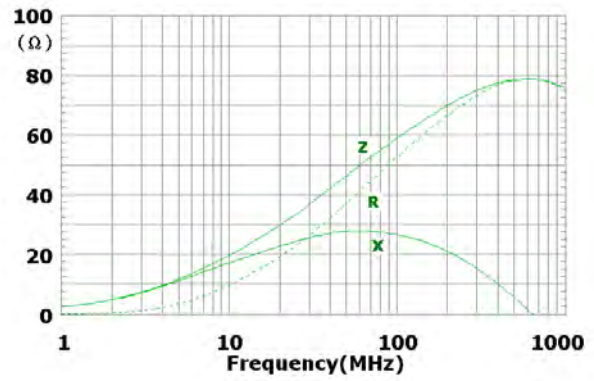

CB04YTYH680

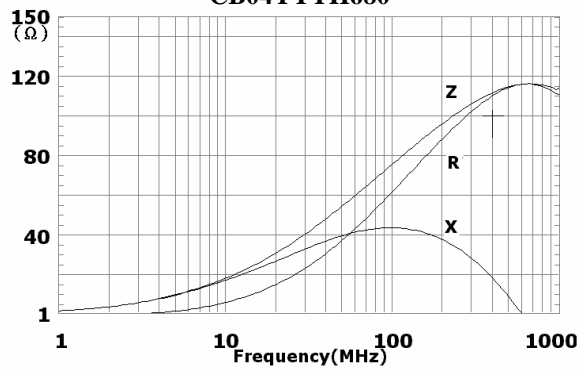

CB04YTYH700

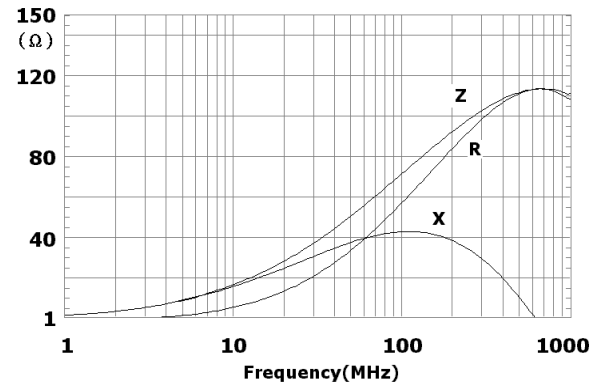

CB04YTYH800

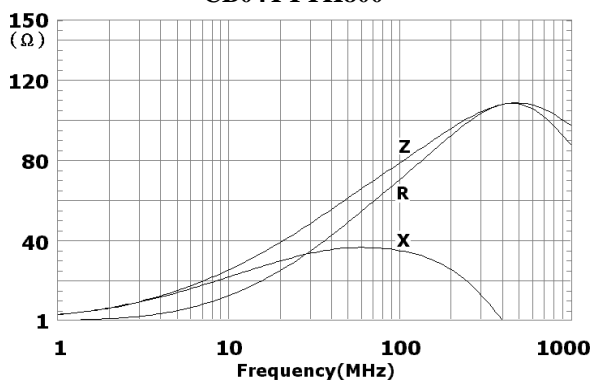

CB04YTYH900

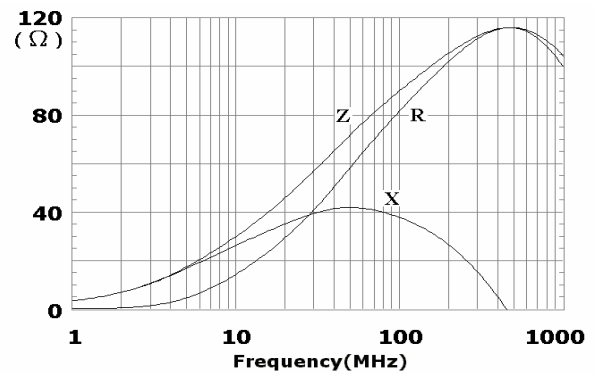

CB04YTYH101

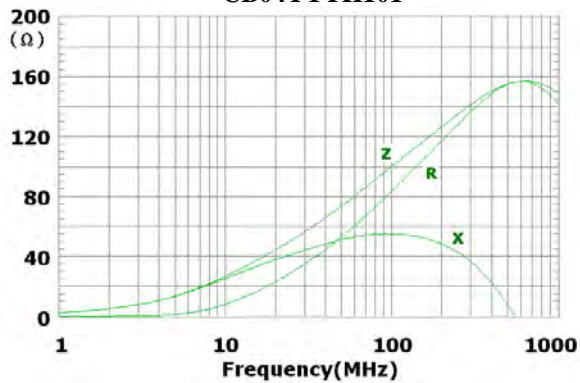

CB04YTYH121

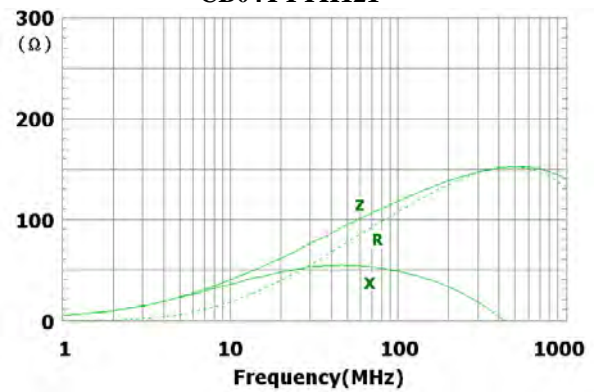

CB04YTYH151

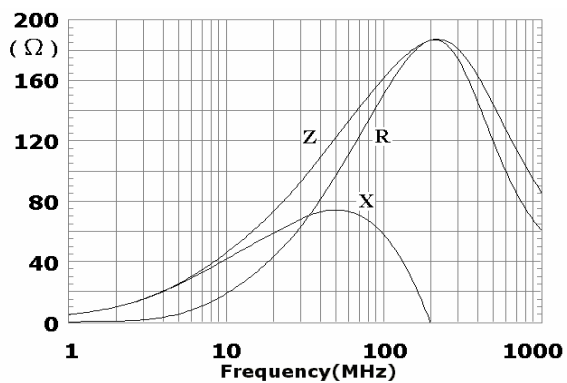

CB04YTYH301

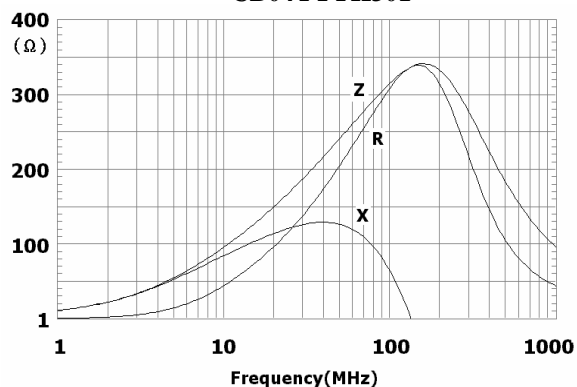

CB04YTYH391

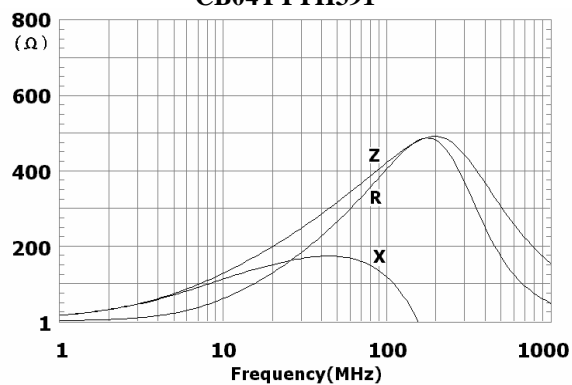

CB04YTYH501

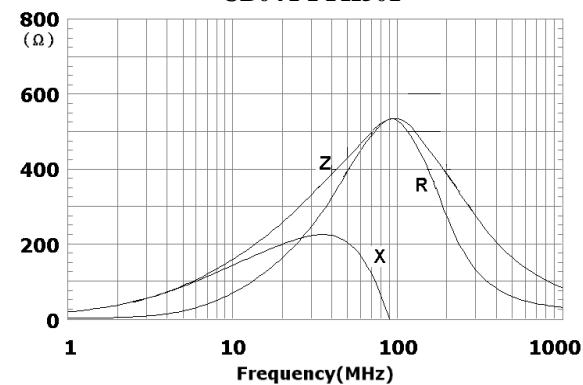

CB04YTYH601

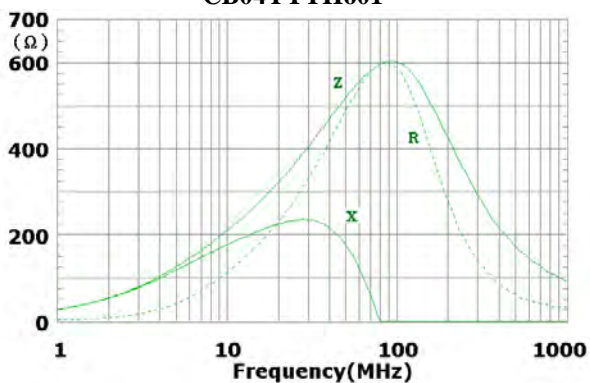

CB04YTYH102

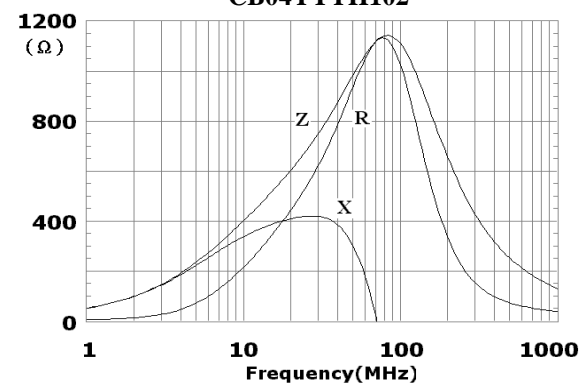

CB04YTYH122

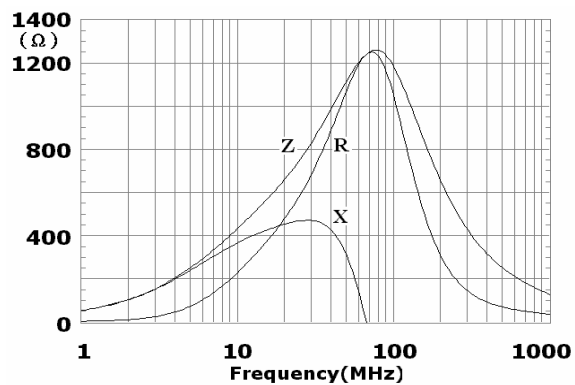

Characteristics (Impedance vs. Frequency) - - CB08YTYH

CB08YTYH500

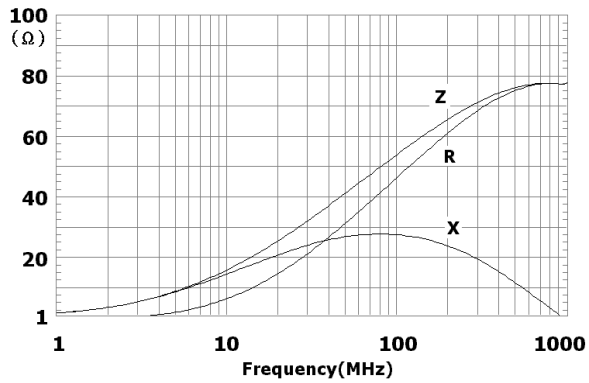

CB08YTYH600

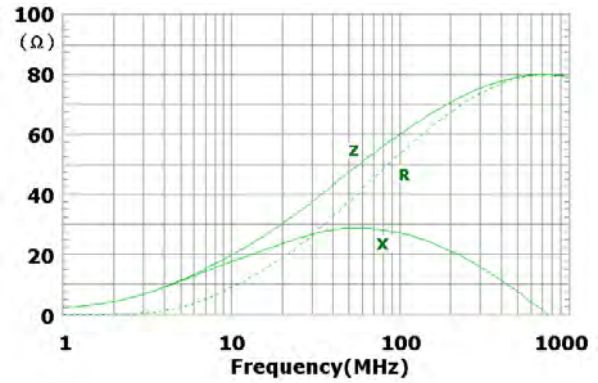

CB08YTYH750

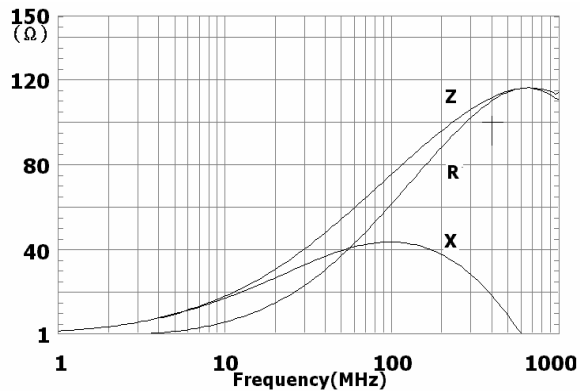

CB08YTYH800

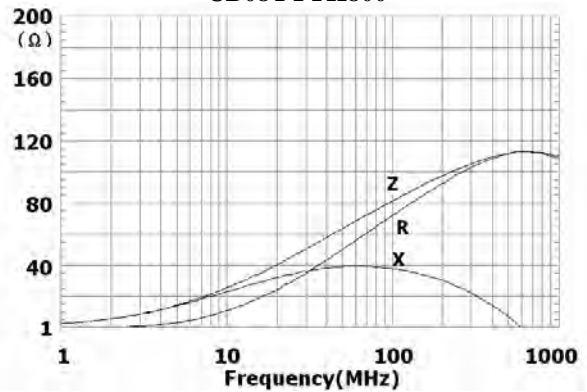

CB08YTYH151

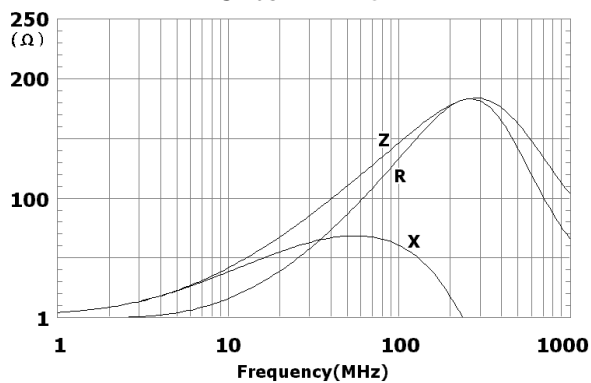

CB08YTYH191

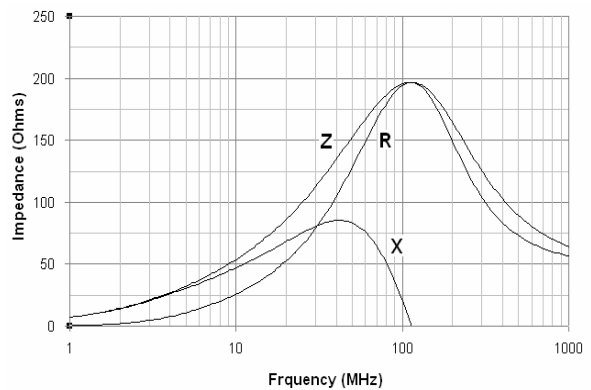

CB08YTYH471

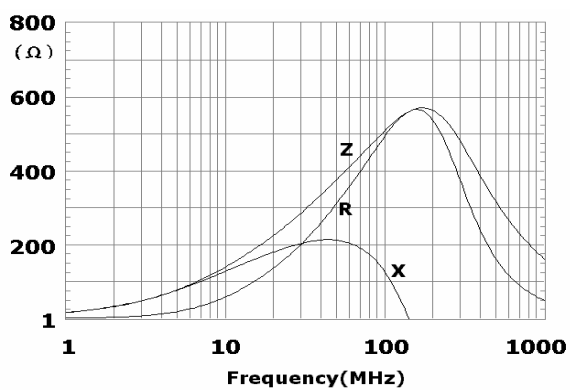

CB08YTYH601

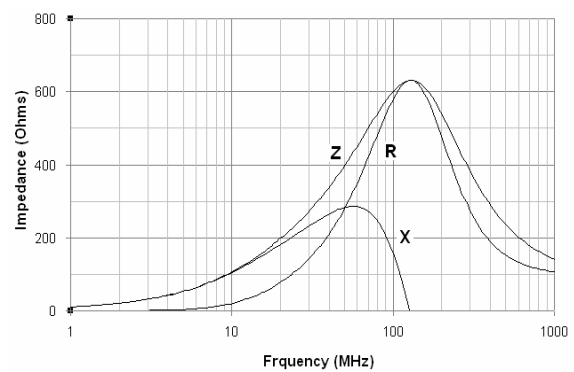

CB08YTYH102

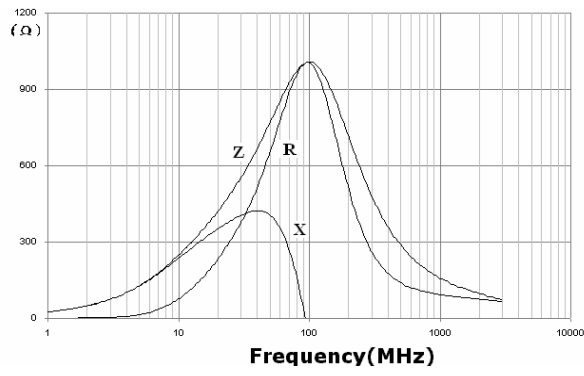

CB08YTYH152

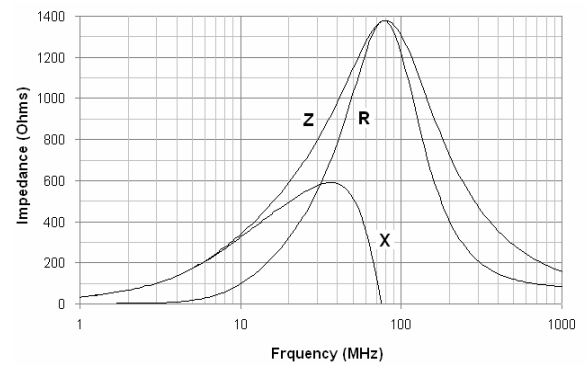

■ Characteristics (Impedance vs. Frequency) - - CB10YTYH

CB10YTYH600

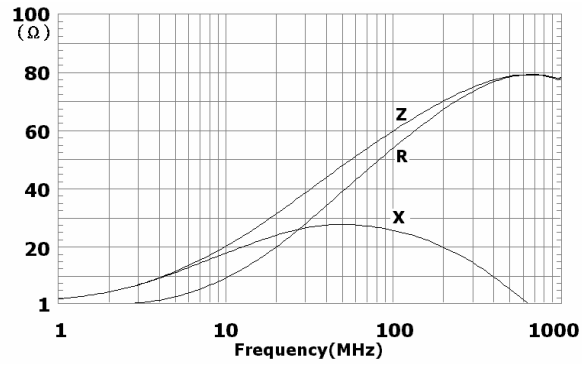

Characteristics (Impedance vs. Frequency) - - CB12YTYH

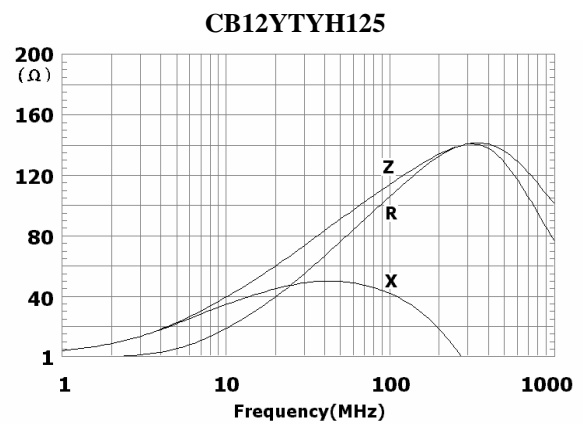
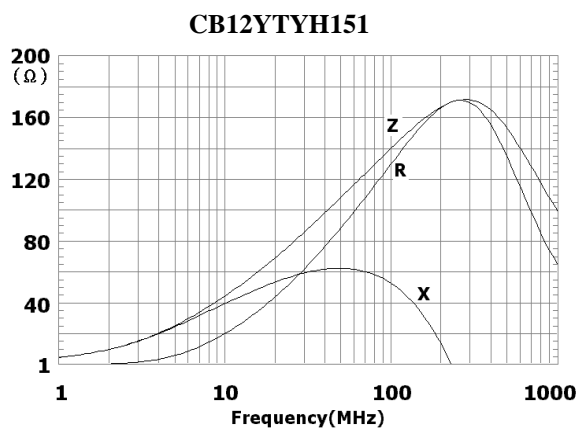
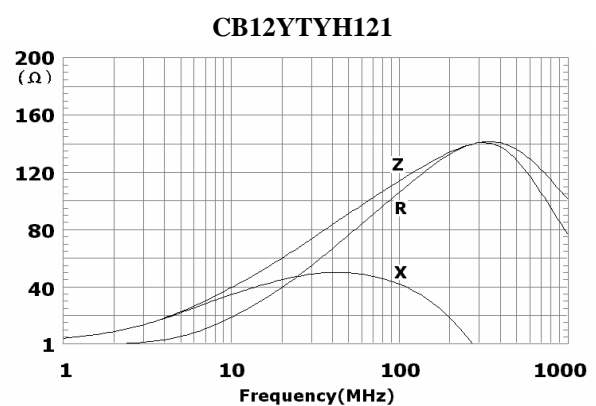
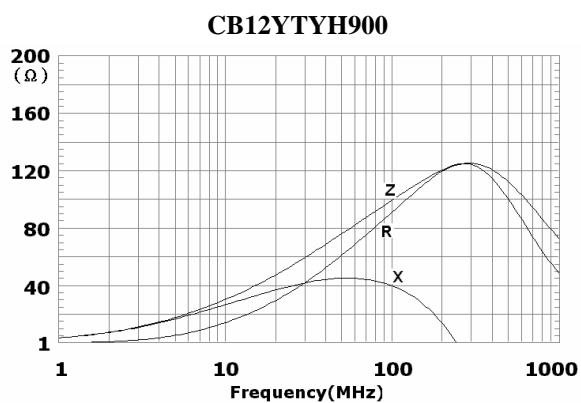
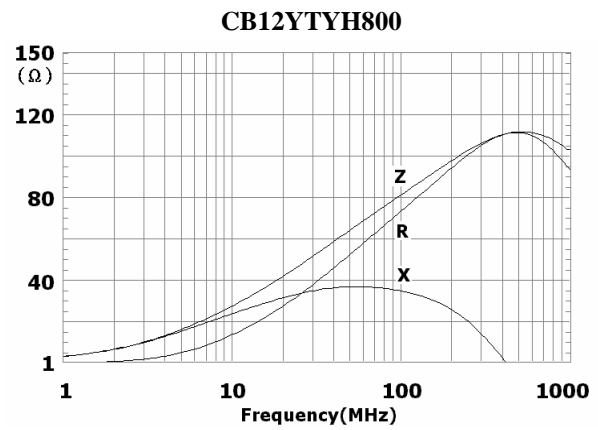
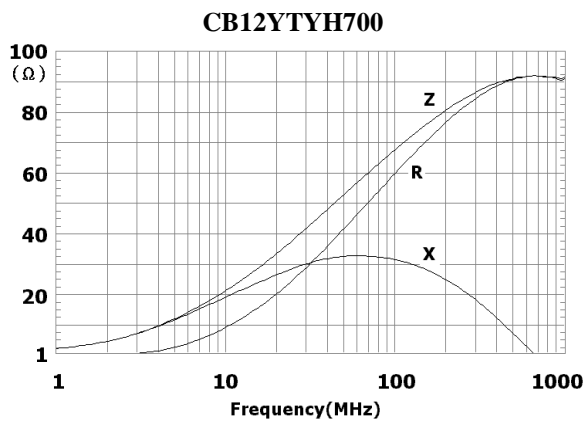
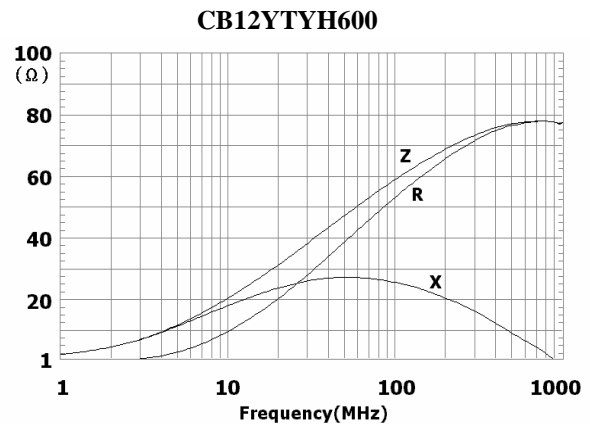
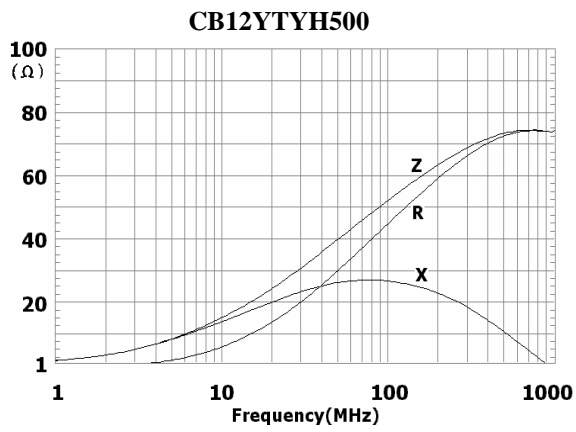

CB12YTYH191

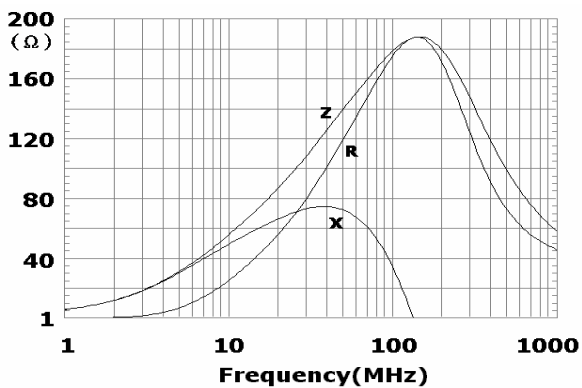

■ Characteristics (Impedance vs. Frequency) - - CB03YTQN

CB03YTQN300

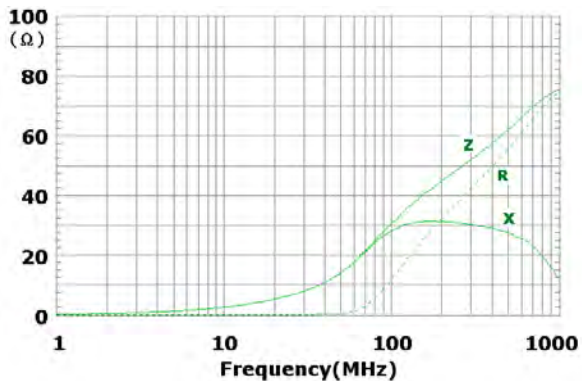

CB03YTQN400

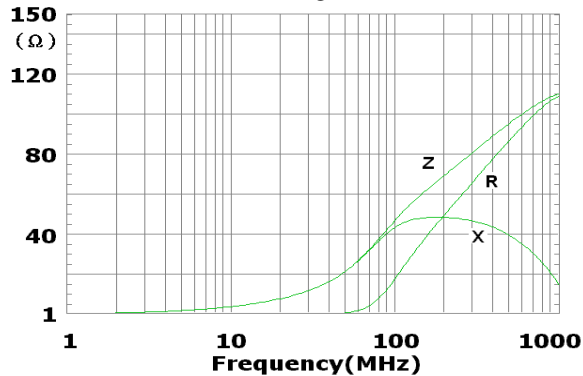

CB03YTQN470

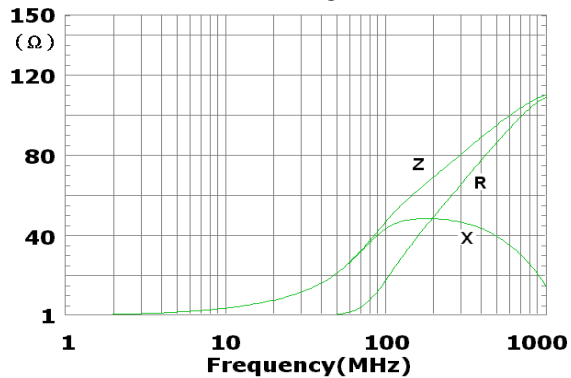

CB03YTQN500

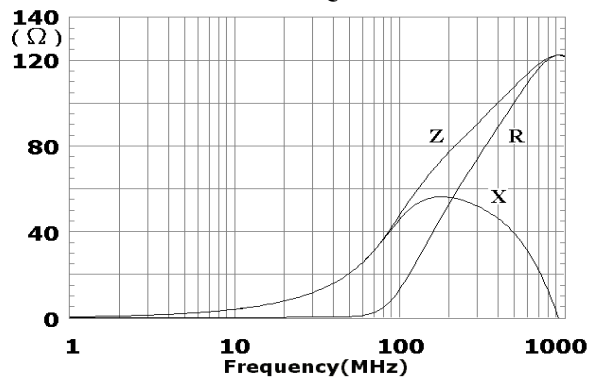

CB03YTQN600

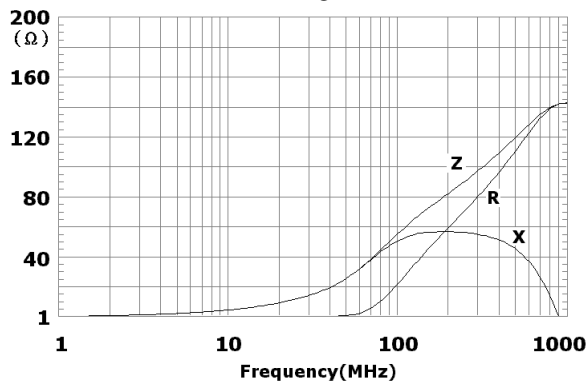

CB03YTQN680

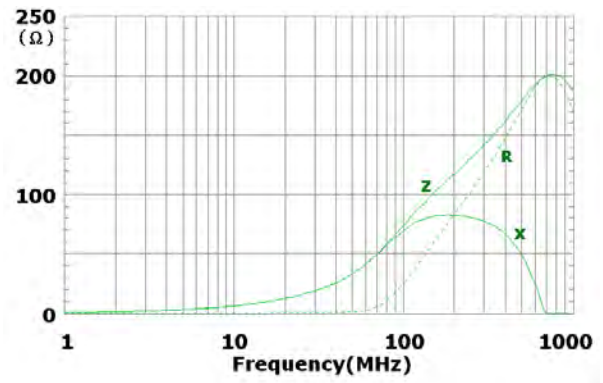

CB03YTQN700

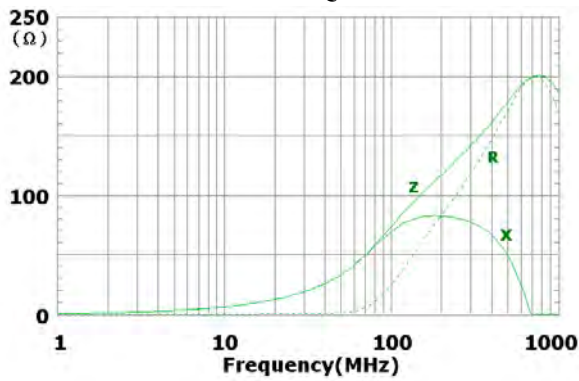

CB03YTQN750

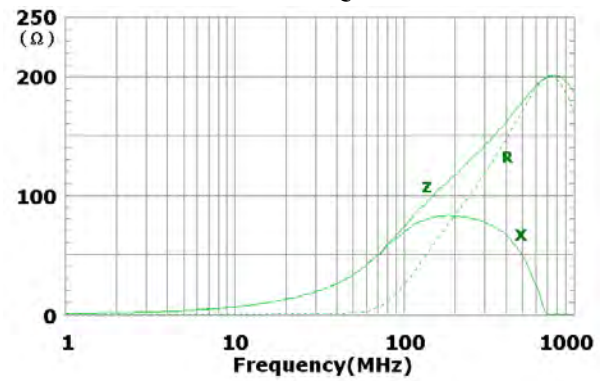

CB03YTQN800

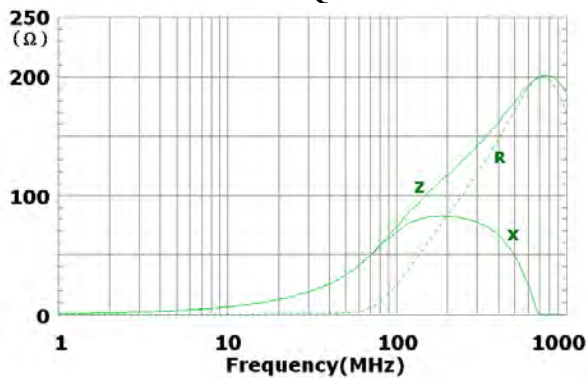

CB03YTQN101

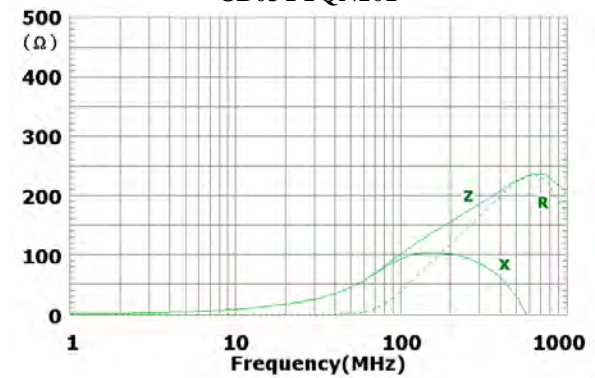

CB03YTQN121

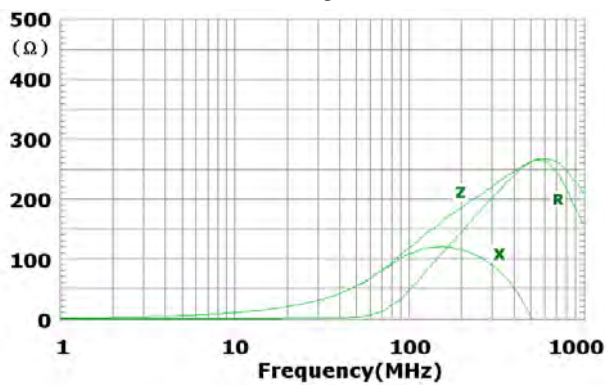

CB03YTQN131

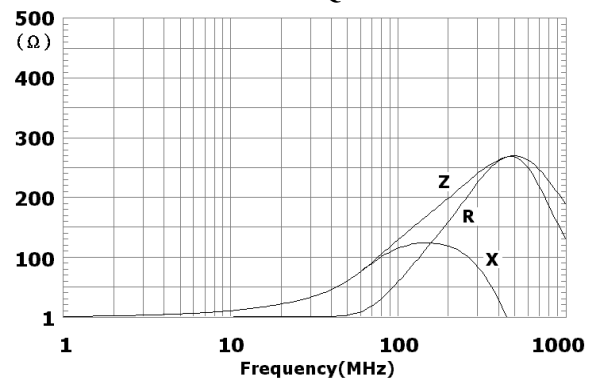

CB03YTQN141

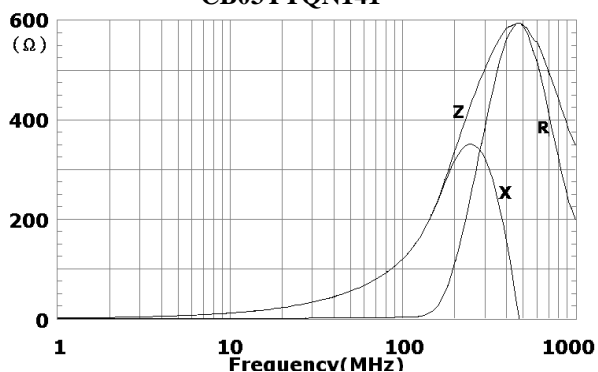

CB03YTQN151

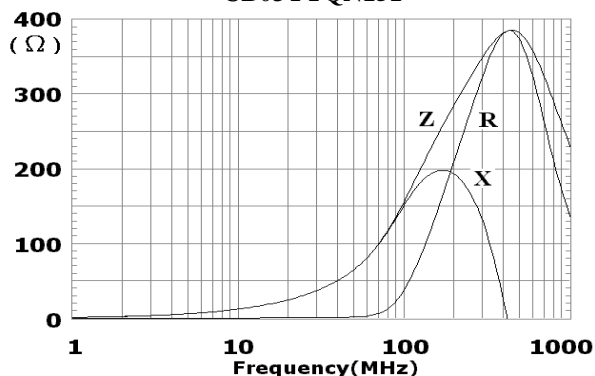

CB03YTQN161

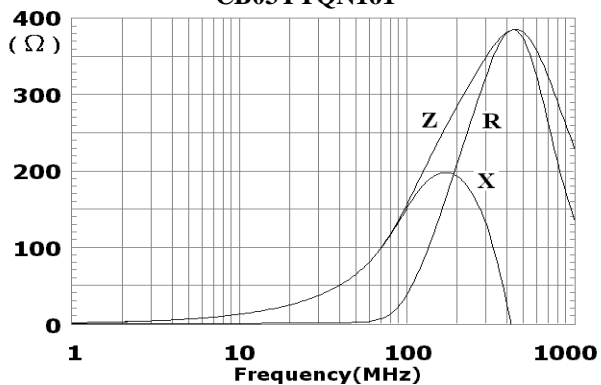

CB03YTQN181

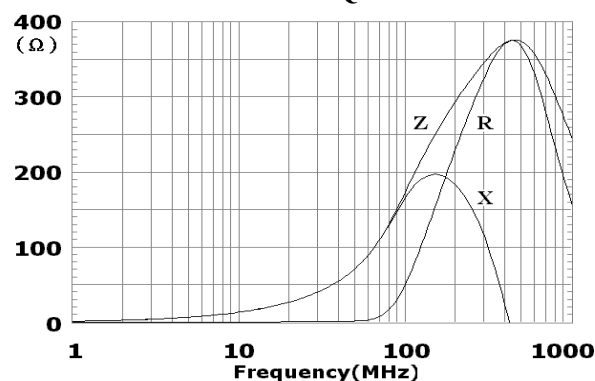

CB03YTQN201

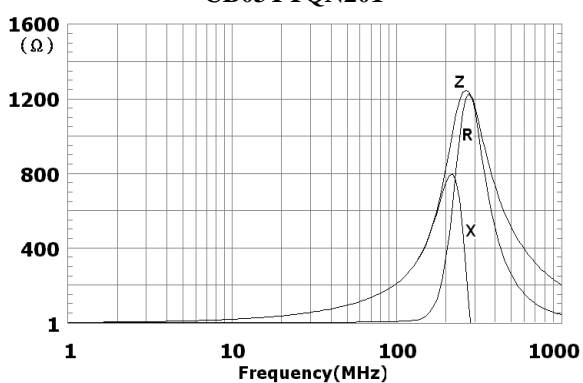

CB03YTQN221

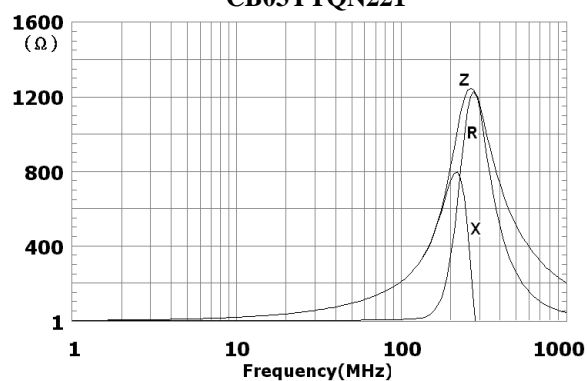

CB03YTQN241

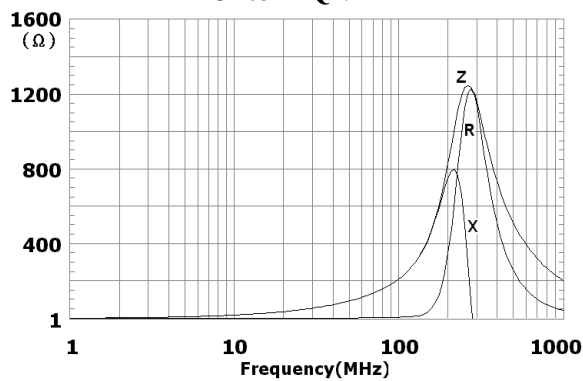

CB03YTQN301

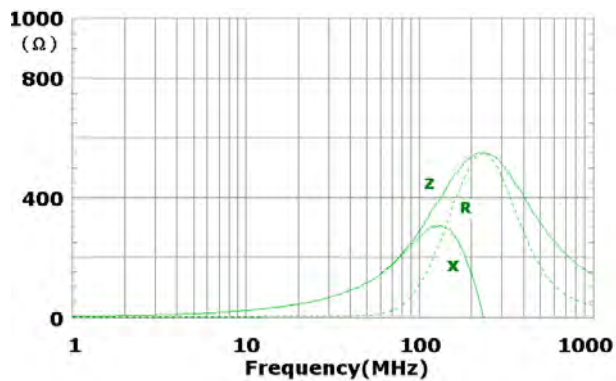

CB03YTQN401

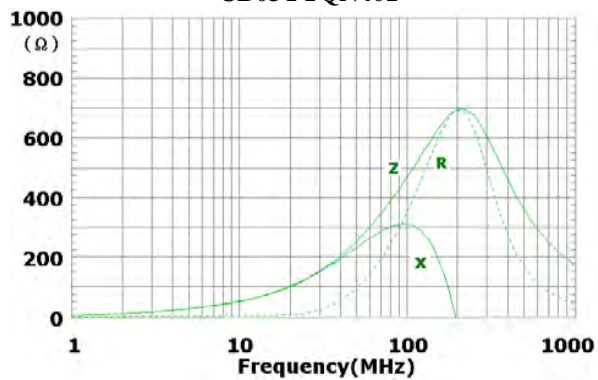

CB03YTQN421

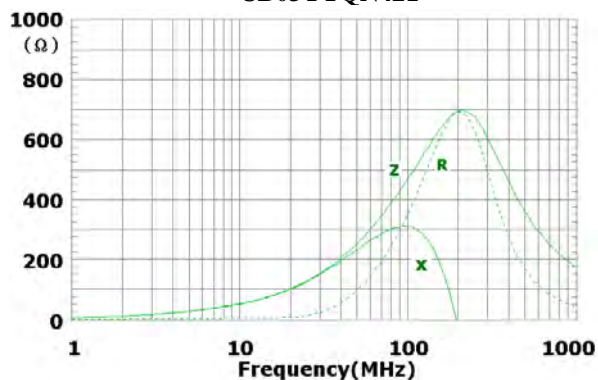

CB03YTQN471

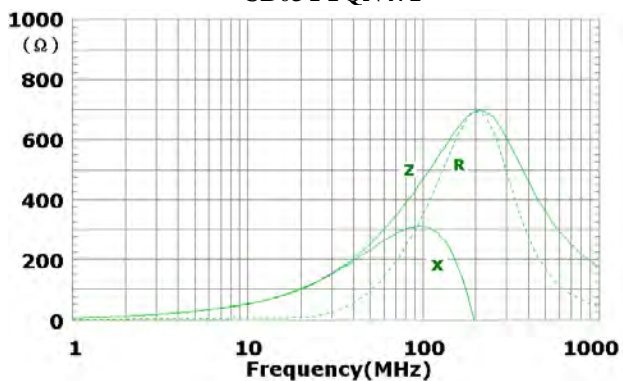

CB03YTQN481

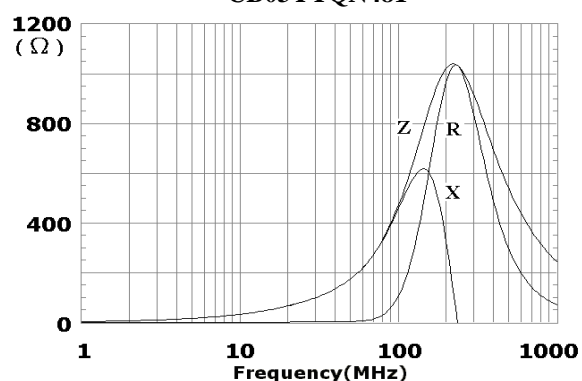

CB03YTQN601

