

SWISSDIS



Swissdis AG
Grasweg 7
CH-4911 Schwarzhäusern

Tel.: +41 62 919 44 00
Fax: +41 62 919 44 01
info@swissdis.ch
www.swissdis.ch



SPECIFICATIONS

Multilayer Chip Inductor

CL-Serie

Version February 2013

Multilayer Chip Inductor

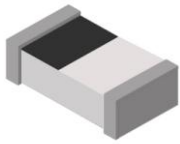

■ Features

- A ceramic material construction for high frequency application up to 10GHz
- Tight tolerance physical dimensions (+/-0.05mm)
- Tight inductance tolerance and excellent Q value
- Available in three compact sizes of 0201, 0402, 0603

■ Applications

- High Frequency Application
- Cellular Phone, Pagers
- EMI Countermeasure in High Frequency Circuits and Computer Communication etc.
- WLAN and RF module

■ Construction

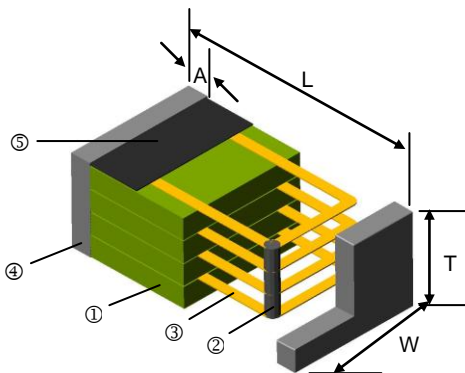

① Ceramic Material	③ Inner Electrode (Ag)	⑤ Direction Mark
② Through Hole	④ End-termination (Ag/Ni/Sn)	

■ Dimensions

Unit: mm

Type	Size (Inch)	L	W	T	A (min. / max.)	Weight (g) (1000pcs)
CL01	0201	0.6±0.03	0.3±0.03	0.33 max.	0.1 / 0.2	0.28
CL02	0402	1.0±0.10	0.5±0.10	0.5±0.10	0.1 / 0.3	0.98
CL03	0603	1.6±0.15	0.8±0.15	0.8±0.15	0.2 / 0.6	3.47

■ Part Numbering

CL	02	J	T	10N
Product Type	Dimensions	Inductance Tolerance	Packaging Code	Inductance
	01: 0201 02: 0402 03: 0603	J: ±5% K: ±10% S: ±0.3nH	T: Taping Reel	1N0: 1.0nH 39N: 39nH R10: 100nH

Electrical Specifications

CL01 Multilayer Chip Inductors Type

Inductance (nH)	Tolerance	Quality Factor /min.	L/Q Freq. (MHz)	Q(Typical) Freq.(MHz)							SRF min. (GHz)	RDC (Ω) max.	IDC (mA) max.
				100	500	800	900	1800	2000	2400			
0.3	±0.3nH	4	100	6	14	19	20	32	35	39	10.0	0.07	250
0.4	±0.3nH	4	100	6	14	19	20	32	35	39	10.0	0.07	250
0.5	±0.3nH	4	100	6	14	19	20	33	36	40	10.0	0.08	250
0.6	±0.3nH	4	100	6	15	19	20	33	36	40	10.0	0.08	250
0.7	±0.3nH	4	100	6	15	20	21	34	37	41	10.0	0.09	250
0.8	±0.3nH	4	100	6	14	19	20	32	35	39	10.0	0.10	250
0.9	±0.3nH	4	100	6	15	20	21	35	37	42	10.0	0.10	250
1.0	±0.3nH	4	100	5	13	17	18	28	30	33	10.0	0.14	250
1.1	±0.3nH	4	100	6	14	18	20	30	32	34	10.0	0.14	250
1.2	±0.3nH	4	100	6	14	18	19	28	30	32	10.0	0.14	250
1.3	±0.3nH	4	100	6	13	17	18	27	28	31	10.0	0.14	250
1.5	±0.3nH	4	100	6	14	18	20	30	32	34	10.0	0.18	230
1.6	±0.3nH	4	100	6	14	18	20	28	30	31	10.0	0.18	230
1.8	±0.3nH	4	100	6	14	18	20	28	30	31	10.0	0.19	200
2.0	±0.3nH	4	100	6	14	18	19	28	29	31	8.8	0.20	200
2.1	±0.3nH	4	100	6	13	17	18	26	28	30	8.8	0.20	200
2.2	±0.3nH	4	100	6	13	17	18	26	28	30	8.8	0.22	200
2.4	±0.3nH	4	100	6	14	18	20	28	29	31	8.3	0.24	200
2.7	±0.3nH	5	100	6	14	18	19	28	29	31	7.7	0.25	200
3.0	±0.3nH	5	100	7	15	19	21	30	31	33	7.2	0.28	180
3.2	±0.3nH	5	100	6	14	19	20	29	30	32	6.7	0.30	180
3.3	±0.3nH	5	100	6	14	19	20	29	30	32	6.7	0.30	180
3.6	±0.3nH	5	100	6	14	18	20	28	29	31	6.4	0.30	170
3.9	±0.3nH	5	100	6	15	19	20	28	29	31	6.0	0.30	170
4.3	±0.3nH	5	100	6	14	18	19	27	28	29	5.7	0.40	150
4.7	±0.3nH	5	100	6	14	19	19	26	27	29	5.3	0.40	150
5.1	±0.3nH	5	100	6	13	17	18	25	25	26	5.0	0.40	150
5.6	±0.3nH	5	100	7	14	18	19	26	27	27	4.2	0.40	150
6.2	±5%	5	100	6	14	18	19	26	26	30	3.8	0.44	150
6.8	±5%	5	100	7	14	18	19	26	26	26	3.5	0.50	150
7.5	±5%	5	100	6	15	18	20	25	25	25	3.3	0.53	150
8.2	±5%	5	100	7	15	18	19	19	24	24	3.2	0.55	150
9.1	±5%	5	100	6	13	16	17	21	20	18	3.0	0.62	150
10	±5%	5	100	6	13	16	17	20	20	18	2.8	0.65	150
12	±5%	5	100	7	13	116	17	18	17	14	2.4	0.70	100
15	±5%	5	100	7	15	18	19	19	17	11	2.2	0.80	100
18	±5%	5	100	7	13	16	16	14	11	5	2.2	0.90	100
22	±5%	5	100	7	13	16	16	12	8	-	1.8	1.20	100
27	±5%	4	100	6	13	15	15	6	-	-	1.8	1.80	50
33	±5%	4	100	7	14	16	17	6	-	-	1.7	2.10	50
39	±5%	4	100	6	12	13	13	-	-	-	1.5	2.40	50
47	±5%	4	100	6	11	12	11	-	-	-	1.3	2.80	100
56	±5%	4	100	6	11	11	10	-	-	-	1.1	3.00	80
68	±5%	4	100	6	11	11	10	-	-	-	1.1	2.66	80
82	±5%	4	100	6	11	10	8	-	-	-	1.0	3.37	70
100	±5%	4	100	6	10	9	6	-	-	-	0.9	3.74	60

Operating temperature range: -55~+125°C

Electrical Specifications

CL02 Multilayer Chip Inductors Type

Inductance (nH)	Tolerance	Quality Factor /min.	L/Q Freq. (MHz)	Q(Typical) Freq.(MHz)							SRF min. (GHz)	RDC (Ω) max.	IDC (mA) max.
				100	500	800	900	1800	2000	2400			
0.6	±0.3nH	8	100	12	40	60	65	100	120	140	10.0	0.08	300
1.0	±0.3nH	8	100	12	29	38	41	63	71	75	10.0	0.08	300
1.1	±0.3nH	8	100	11	29	37	40	60	67	72	10.0	0.08	300
1.2	±0.3nH	8	100	11	29	38	41	61	68	73	10.0	0.09	300
1.3	±0.3nH	8	100	11	30	38	41	61	67	72	10.0	0.09	300
1.5	±0.3nH	8	100	11	27	35	38	57	63	68	10.0	0.10	300
1.6	±0.3nH	8	100	11	28	35	38	57	64	68	10.0	0.10	300
1.8	±0.3nH	8	100	11	26	33	36	53	58	61	6.00	0.12	300
2.0	±0.3nH	8	100	10	23	29	31	45	49	52	6.00	0.12	300
2.2	±0.3nH	8	100	10	24	31	33	48	52	55	6.00	0.13	300
2.4	±0.3nH	8	100	10	25	31	34	49	53	57	6.00	0.13	300
2.7	±0.3nH	8	100	11	27	35	37	54	58	60	6.00	0.16	300
3.0	±0.3nH	8	100	10	25	32	34	49	53	55	6.00	0.16	300
3.3	±0.3nH, ±10%	8	100	11	25	32	35	50	54	56	6.00	0.16	300
3.6	±0.3nH, ±10%	8	100	10	24	31	33	46	49	49	5.00	0.20	300
3.9	±0.3nH, ±10%	8	100	11	24	30	33	46	49	51	4.00	0.20	300
4.3	±0.3nH, ±10%	8	100	11	26	33	35	50	53	54	4.00	0.20	300
4.7	±0.3nH, ±10%	8	100	11	25	32	35	49	51	53	4.00	0.20	300
5.1	±0.3nH, ±10%	8	100	11	25	32	35	46	48	49	4.00	0.23	300
5.6	±0.3nH, ±10%	8	100	11	25	32	35	46	48	49	4.00	0.23	300
6.2	±0.3nH, ±10%	8	100	11	26	32	34	46	48	49	3.90	0.25	300
6.8	±5%, ±10%	8	100	11	26	32	35	46	48	48	3.90	0.25	300
7.5	±5%, ±10%	8	100	11	26	32	35	46	48	48	3.70	0.28	300
8.2	±5%, ±10%	8	100	11	26	32	34	42	42	40	3.50	0.28	300
9.1	±5%, ±10%	8	100	11	25	31	34	42	42	40	3.40	0.30	300
10	±5%, ±10%	8	100	11	23	29	31	37	37	34	3.20	0.31	300
12	±5%, ±10%	8	100	11	24	31	33	37	36	30	2.60	0.45	300
15	±5%, ±10%	8	100	11	23	30	32	35	33	28	2.30	0.55	300
18	±5%, ±10%	8	100	11	23	28	29	30	28	22	2.00	0.65	300
22	±5%, ±10%	8	100	11	22	27	28	22	18	6	1.60	0.70	300
27	±5%, ±10%	8	100	11	22	26	27	16	11	4	1.40	0.80	300
33	±5%, ±10%	8	100	11	22	25	26	12	5	-	1.20	0.90	200
39	±5%, ±10%	8	100	11	20	22	22	-	-	-	1.10	1.00	200
47	±5%, ±10%	8	100	11	20	21	21	-	-	-	0.90	1.10	200
56	±5%, ±10%	8	100	11	19	19	18	-	-	-	0.75	1.10	200
68	±5%, ±10%	8	100	11	18	17	15	-	-	-	0.75	1.20	180
82	±5%, ±10%	8	100	11	18	15	12	-	-	-	0.60	1.30	150
100	±5%, ±10%	8	100	11	17	12	9	-	-	-	0.60	1.60	150
120	±5%, ±10%	8	100	11	16	7	-	-	-	-	0.60	1.60	150
150	±5%, ±10%	8	100	11	14	-	-	-	-	-	0.55	2.40	140
180	±5%, ±10%	8	100	12	-	-	-	-	-	-	0.50	3.70	130
220	±5%, ±10%	8	100	12	-	-	-	-	-	-	0.45	4.20	120
270	±5%, ±10%	8	100	12	-	-	-	-	-	-	0.40	4.80	110

Operating temperature range: -55~+125°C

■ Electrical Specifications

CL03 Multilayer Chip Inductors Type

Inductance (nH)	Tolerance	Quality Factor /min.	L/Q Freq. (MHz)	Q (Typical) Freq.(MHz)							SRF (GHz) Min.	RDC (Ω) Max.	IDC (mA) Max.
				100	500	800	900	1800	2000	2400			
1.0	±0.3nH	8	100	14	40	53	60	93	32	174	10.0	0.05	1000
1.2	±0.3nH	8	100	15	38	49	54	84	32	143	10.0	0.05	1000
1.5	±0.3nH	8	100	12	31	39	43	62	33	88	10.0	0.10	1000
1.8	±0.3nH	8	100	13	34	42	46	68	37	97	10.0	0.10	1000
2.2	±0.3nH	8	100	14	36	46	50	73	42	101	6.00	0.10	1000
2.7	±0.3nH	10	100	14	36	47	45	72	45	94	6.00	0.13	1000
3.3	±0.3nH, ±10%	10	100	14	37	47	50	67	47	77	6.00	0.13	1000
3.9	±0.3nH, ±10%	10	100	15	36	46	49	66	48	81	6.00	0.15	1000
4.7	±0.3nH, ±10%	10	100	15	39	50	53	70	53	80	4.00	0.20	1000
5.6	±0.3nH, ±10%	10	100	15	39	50	54	67	52	69	4.00	0.23	600
6.8	±5%, ±10%	10	100	15	38	49	52	66	53	66	4.00	0.25	600
8.2	±5%, ±10%	10	100	16	37	48	50	59	49	54	3.50	0.28	600
10	±5%, ±10%	12	100	16	39	49	52	60	50	52	3.20	0.30	600
12	±5%, ±10%	12	100	16	36	46	48	47	39	31	2.60	0.35	600
15	±5%, ±10%	12	100	17	40	50	52	49	41	31	2.30	0.40	600
18	±5%, ±10%	12	100	17	39	48	50	43	35	21	2.00	0.45	600
22	±5%, ±10%	12	100	17	39	46	47	29	19	1	1.60	0.50	600
27	±5%, ±10%	12	100	18	39	45	46	19	8	-	1.40	0.55	600
33	±5%, ±10%	12	100	18	39	43	43	-	-	-	1.20	0.60	600
39	±5%, ±10%	12	100	19	36	39	37	-	-	-	1.10	0.65	500
47	±5%, ±10%	12	100	17	34	36	34	-	-	-	0.90	0.70	500
56	±5%, ±10%	12	100	19	35	34	31	-	-	-	0.90	0.75	500
68	±5%, ±10%	12	100	18	33	29	25	-	-	-	0.70	0.85	400
82	±5%, ±10%	12	100	19	32	25	20	-	-	-	0.60	0.95	300
100	±5%, ±10%	12	100	18	30	19	12	-	-	-	0.60	1.00	300
120	±5%, ±10%	8	50	19	28	14	-	-	-	-	0.50	1.20	300
150	±5%, ±10%	8	50	18	21	-	-	-	-	-	0.50	1.20	300
180	±5%, ±10%	8	50	17	17	-	-	-	-	-	0.40	1.30	300
220	±5%, ±10%	8	50	16	13	-	-	-	-	-	0.40	1.50	300
240	±5%, ±10%	8	50	16	-	-	-	-	-	-	0.40	1.70	200
270	±5%, ±10%	8	50	16	-	-	-	-	-	-	0.40	1.90	150
330	±5%, ±10%	8	50	14	-	-	-	-	-	-	0.35	2.10	150
390	±5%, ±10%	8	50	14	-	-	-	-	-	-	0.35	2.30	150
470	±5%, ±10%	8	50	13	-	-	-	-	-	-	0.30	2.60	150

■ Operating temperature range: -40~+85°C

Environmental Characteristics

Electrical Performance Test

Item	Requirement	Test Condition
Inductance	In Within specified tolerance	Temperature: 25±1°C Relative Humidity: 45 to 85%RH Atmospheric Pressure: 86 to 106kpa Measuring equipment and fixture: 0201: HP4291B+Agilent16196C 0402: HP4291B+Agilent16193A 0603: HP4291B+Agilent16192A
Q Value	In accordance with electrical specification	Temperature: 25±1°C Relative Humidity: 45 to 85%RH Atmospheric Pressure: 86 to 106kpa
DC Resistance	In accordance with electrical specification	Temperature: 25±1°C Relative Humidity: 45 to 85%RH Atmospheric Pressure: 86 to 106kpa Measuring equipment: HP 4338
Temperature Characteristics	Within specified tolerance	Temperature range: -30 to+ 85°C Reference temperature: 25°C

Mechanical Characteristics Test

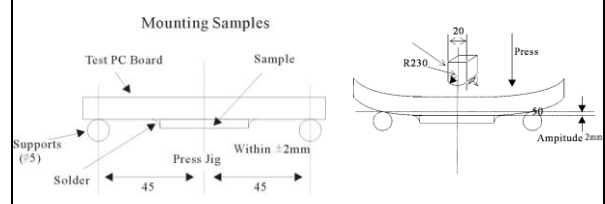
Item	Requirement	Test Condition
Bending Strength	No mechanical damage shall be observed	Solder the chip to test jig then apply a force in the direction shown in below. The soldering shall be done with the reflow method and shall be conducted with care so that the soldering is uniform and free of defects such as heat shock. 
Solderability	More than 75% of the terminal electrode part shall be covered with fresh solder	Immerse a test sample into a methanol solution containing rosin, preheat it at 150 to 180°C for 3 to 5 seconds and immerse into molten solder of 245±5°C for 5±0.5 seconds.
Resistance to Soldering Heat	No visible damage	Immerse a test sample into a methanol solution containing rosin, preheat it at 150 to 180°C for 2 to 3 minutes and immerse into molten solder of 260±5°C for 10±0.5 seconds so that both terminal electrodes are completely submerged.
Appearance	In accordance with specification	Inductors shall be visually inspected for visible evidence of defect
Dimension	In accordance with dimension specification	Dimension shall be measured with caliper or micrometer

Climatic Test

Item	Requirements	Test Condition
Thermal Shock	No visible damage Inductance variation within 10% Q variation within 20%	Solder a test sample to printed circuit board, and conduct 100 cycles of test under the conditions shown as below. Cycle: 100°C/1hr -40°C/1hr
High Humidity State Life Test	No visible damage. Inductance variation within 10%. Q variation within 20%.	Keep a test sample in an atmosphere with a temperature of 70±2°C, 90~95%RH for 500±12 hours. After the test, keep the test sample at a normal temperature for 1 to 2 hours, and then carry out measurement.
High Humidity Load Life Test	No visible damage. Inductance variation within 10%. Q variation within 20%.	Solder a test sample to printed circuit board then keep the test sample in an atmosphere with a temperature of 70±2°C, 90~95%RH for 500±12 hours while supplying the rated current. After the test, keep the test sample at a normal temperature for 1 to 2 hours, and then carry out measurement.
High Temperature State Life Test	No visible damage. Inductance variation within 10%. Q variation within 20%.	Keep a test sample in an atmosphere with a temperature of 100±2°C for 500±12 hours. After the test, keep the test sample at a normal temperature for 1 to 2 hours, and then carry out measurement.
High Temperature Load	No visible damage. Inductance variation within 10%. Q variation within 20%.	Solder a test sample to printed circuit board then keep the test sample in an atmosphere with a temperature of 100±2°C for 500±12 hours while supplying the rated current. After the test, keep the test sample at a normal temperature for 1 to 2 hours, and then carry out measurement.

■ Packaging Specifications

Reel Dimensions

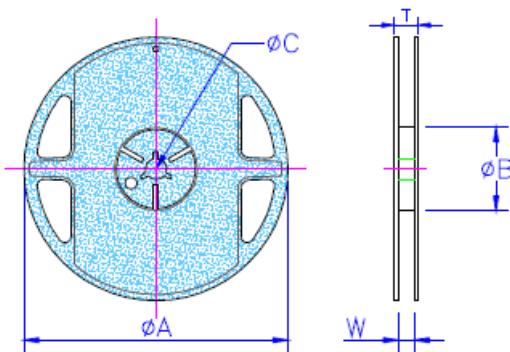

Unit: mm

Type	A	B	C	W	T	Quantity (EA)
CL01	178±1	60.0±0.5	13.0±0.20	9.00±0.5	12.0±0.15	15,000
CL02	178±1	60.0±0.5	13.0±0.20	9.00±0.5	12.0±0.15	10,000
CL03	178±1	60.0±0.5	13.0±0.20	9.00±0.5	12.0±0.15	4,000

Tape Specifications

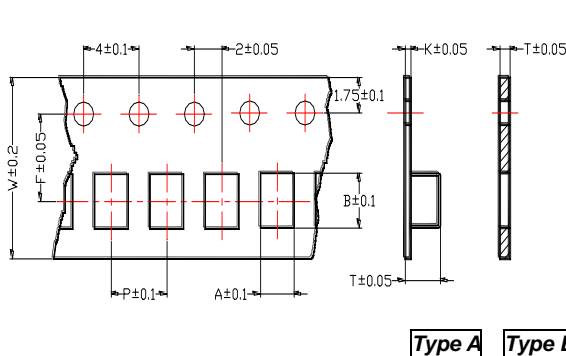

Unit: mm

Type	A	B	T	W	P	F	K	Tape
CL01	0.38	0.68	0.42	8	2	3.5	-	B
CL02	0.65	1.12	0.60	8	2	3.5	-	B
CL03	1.10	1.80	0.95	8	4	3.5	-	B

Type A **Type B**