

SWISSDIS



Swissdis AG
Grasweg 7
CH-4911 Schwarzhäusern

Tel.: +41 62 919 44 00
Fax: +41 62 919 44 01
info@swissdis.ch
www.swissdis.ch



SPECIFICATIONS

SMD Power Inductor

MLPH08MT2R2

Version April 2019

**Wire Wound Type Power Inductor
Wire Wound Type Power Inductor**

■ Features

- High saturation current realized by material properties and structure design
- Low DC resistance to achieve high conversion efficiency and lower temperature rising
- Magnetically shielded structure to accomplish high resolution in EMC protection
- Halogen free, Lead Free, RoHS Compliance

■ Applications

- Smart phone, PAD
- Thin-type power supply module
- DC-DC Converters

■ Dimensions

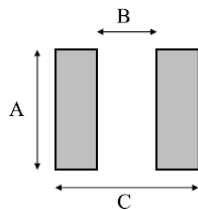
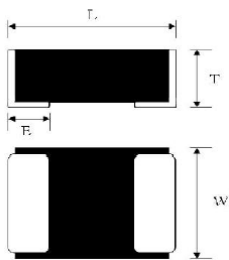

Unit: mm

Type	Size (Inch)	L	W	T	E	A	B	C
MLP(H)08	1008	2.50±0.20	2.00±0.20	1.20 max	0.60±0.20	2.0	1.2	2.8

■ Part Numbering

MLPH	08	M	T	2R2
Product Type	Dimensions	Inductance Tolerance	Packaging Code	Inductance
MLPH: High Current	08: 1008	M: ±20%	T: Taping Reel	2R2: 2.2uH

■ High Current Electrical Specifications

Part No	Inductance (uH)	Tolerance	Test Condition	DCR (mΩ) max.	Isat (A) max.	Irms (A) max.
MLPH08MT2R2	2.2	±20%	1MHz, 1V	89	3.20	2.20

Operating Temperature range : -40°C to +125°C

Wire Wound Type Power Inductor

Environmental Characteristics

Electrical Performance Test

Item	Requirement	Test Method
Inductance	Refer to standard electrical characteristic spec.	HP4285A
DC Resistance RDC		micro-ohm meter
Isat		DC current will cause a 30% inductance reduction form initial value
Irms		DC current will cause coil temp. rising to 40°C whichever is smaller

Mechanical Performance Test

Item	Requirement	Test Method
Resistance to Soldering Heat	Appearance: No damage More than 95% of the terminal. Electrode should be covered with solder. Inductance: within ±20% of initial value	Flux: Rosin Solder Temperature: 260±5°C Immersion Time: 10±1 sec.
Adhesive Test	No mechanical damage Soldering the products on PCB after the pulling test force>5N	Reflow temperature: 245°C it shall be soldered on the substrate applying direction parallel to the substrate Apply force(F) : 5 N Test time : 10 sec
Temperature Cycle	No mechanical damage Inductance: within ±20% of initial value	Temperature: -50~125°C for 30 minutes each Cycle: 500cycles Measurement: at ambient temperature 24 hours after test completion
Dry Heat Test		Temperature: 85±2°C Testing time: 500 hrs Applied current: full rated current Measurement: at ambient temperature 24 hours after test completion
Humidity Test		Temperature: 60±2°C, Humidity: 90~95% RH Testing time: 500 hrs Applied current: full rated current Measurement: at ambient temperature 24 hours after test completion

Recommendable Reflow Soldering

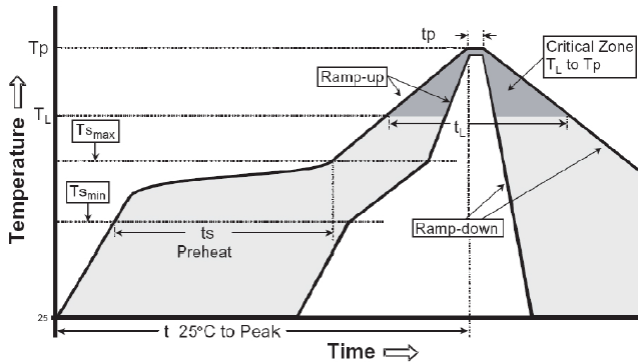

Reference IPC-020c-5-1

Profile Feature	Pb free Assembly
Average Ramp Rate (Ts max to Tp)	3 °C/second max
Preheat	
- Temperature Min (Ts _{min})	150°C
- Temperature Min (Ts _{max})	200°C
- Time (ts _{min} to ts _{min})	60-180 seconds
Time maintained above:	
- Temperature (TL)	217°C
- Time (tL)	60-150 seconds
Peak Temperature (Tp)	260°C +0/-5 °C
Time within 5 °C of actual Peak Temperature (Tp)	20-40 seconds
Ramp-Down Rate	6 °C/second max.
Time 25°C to Peak Temperature	8 minutes max

Wire Wound Type Power Inductor

■Packaging

Reel Specifications

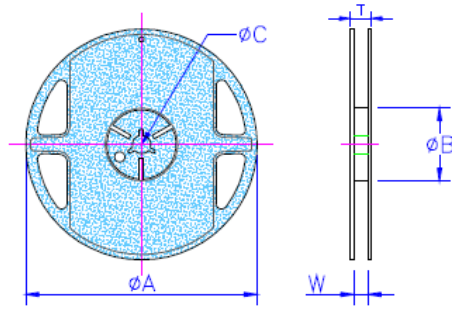

Unit: mm

Type	A	B	C	W	T	Quantity (EA)
MLP(H)08	178±1	60.0+0.5	13.0±0.2	9.00±0.5	12.0±0.5	3,000

Tape Specifications

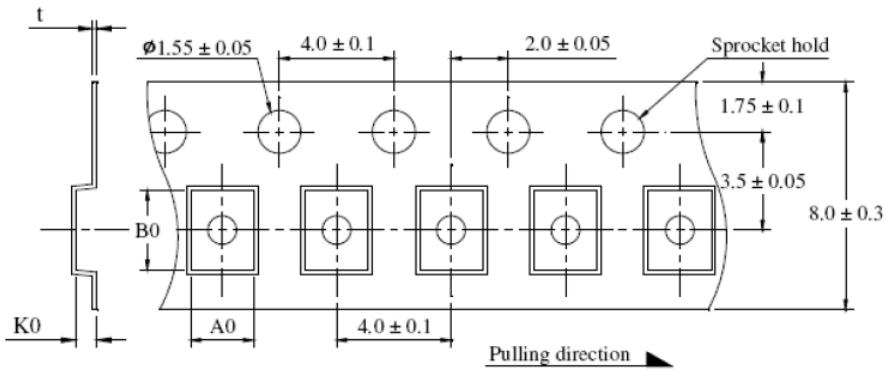

Unit: mm

Type	A0	B0	K0	t
MLPH08	2.25±0.05	2.80±0.10	1.35±0.10	0.22±0.05