

SWISSDIS



Swissdis AG
Grasweg 7
CH-4911 Schwarzhäusern

Tel.: +41 62 919 44 00
Fax: +41 62 919 44 01
info@swissdis.ch
www.swissdis.ch



SPECIFICATIONS

Thin Film Chip High Power

ARP-Series

Version January 2022

High Power Thin Film Chip Resistors (ARP Series)



■Features

- Wider bottom terminal enabling higher power capability (short side terminal)
- Significantly larger power handling capability than existing same size resistors
- Size: 1206, Power rating: 1.0W, Resistance range: 10 ~ 100KΩ
- AEC-Q200 Compliance
- Advanced sulfur resistance verified according to ASTM B 809

■Applications

- Power source related devices
- DC motors, inverters
- Robotics, Industrial control system

■Construction

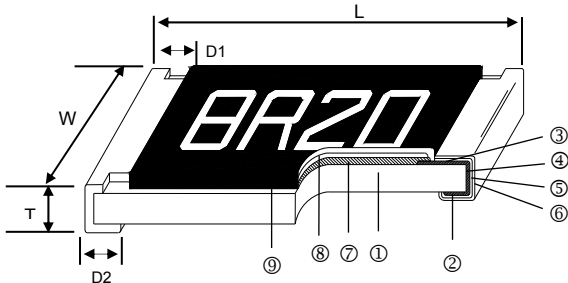

① Alumina Substrate	④ Edge Electrode	⑦ Resistor Layer
② Bottom Electrode	⑤ Barrier Layer	⑧ Overcoat
③ Top Electrode	⑥ External Electrode	⑨ Marking

■Dimensions

Unit: mm

Type	Size (Inch)	L	W	T	D1	D2	Weight (g) (1000pcs)
ARP06	1206	3.05±0.15	1.55±0.15	0.55±0.10	0.42±0.20	1.10±0.20	9.02

■Part Numbering

ARP	06	B	T	C		1001	N
Product Type	Dimensions (L×W)	Resistance Tolerance	Packaging Code	TCR (PPM/°C)	Power Rating	Resistance	Marking Code
	06: 1206	B: ±0.1% D: ±0.5% F: ±1%	T: Taping Reel B: Bulk	C: ±25 D: ±50	: Standard	0100: 10Ω 10R2: 10.2Ω 1000: 100Ω 1001: 1KΩ 1003: 100KΩ	: Standard Marking for E96 / E24 N: No Marking

Derating Curve

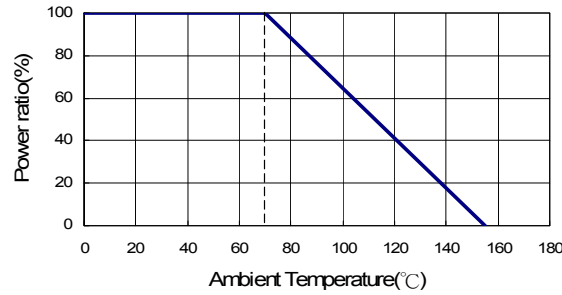

Standard Electrical Specifications

Type	Item	Power Rating at 70°C	Operating Temp. Range	Max. Operating Voltage	Max. Overload Voltage	Resistance Range			TCR (PPM/°C)
						±0.1%	±0.5%	±1%	
1206	1W	-55 ~ +155°C	200V	400V	47Ω – 100KΩ			±25	
					47Ω – 100KΩ	10Ω – 100KΩ	±50		

Operating Voltage= $\sqrt{P \cdot R}$ or Max. operating voltage listed above, whichever is lower.
 Overload Voltage= $2.5 \cdot \sqrt{P \cdot R}$ or Max. overload voltage listed above, whichever is lower.
 ■Viking is capable of manufacturing the optional spec based on customer's requirement.

Environmental Characteristics

Item	Requirement	Test Method
Temperature Coefficient of Resistance (T.C.R.)	As Spec.	MIL-STD-202 Method 304 +25/-55/+25/+125/+25°C
Short Time Overload	<47Ω ΔR±0.4% ; ≥47Ω ΔR±0.2%	JIS-C-5201-1 4.13 RCWV*2.5 or Max. overload voltage whichever is lower for 5 seconds
Insulation Resistance	>1000 MΩ	MIL-STD-202 Method 302 Apply 100V _{DC} for 1 minute
Endurance	<47Ω ΔR±0.5% ; ≥47Ω ΔR±0.25%	MIL-STD-202 Method 108 70±2°C, RCWV for 1000 hrs with 1.5 hrs "ON" and 0.5 hrs "OFF"
High Temperature Exposure	<47Ω ΔR±0.25% ; ≥47Ω ΔR±0.1%	MIL-STD-202 Method 108 at +155°C for 1000 hrs
Biased Humidity	<47Ω ΔR±0.25% ; ≥47Ω ΔR±0.1%	MIL-STD-202 Method 103 1000 hrs 85°C/85%RH 10% of operating power
Temperature Cycling	<47Ω ΔR±0.25% ; ≥47Ω ΔR±0.1%	JESD22 Method JA-104 -55°C to +125°C, 1000 cycles
Bending Strength (Board Flex)	ΔR±0.1%	JIS-C-5201-1 4.33 Bending once for 60 seconds Bending displacement: 0805 sizes: 3 mm

Solderability	95% min. coverage	JIS-C-5201-1 4.17 IEC-60115-1 4.17 245±5°C for 3 seconds
Resistance to Soldering Heat	<47Ω ΔR±0.25% ; ≥47Ω ΔR±0.1%	JIS-C-5201-1 4.18 IEC-60115-1 4.18 260±5°C for 10 seconds
Terminal strength	No broken	AEC-Q200-006 Force of 1.8kg for 60 seconds.
Mechanical Shock	ΔR±0.1%	MIL-STD-202 Method 213 Wave Form: Tolerance for half sine shock pulse. Peak value is 100g's. Normal duration (D) is 6.
Vibration	ΔR±0.1%	MIL-STD-202 Method 204 5 g's for 20 min., 12 cycles each of 3 orientations, 10-2000 Hz
ESD	ΔR±0.5%	AEC-Q200-002 Human body model 1206 : 1KV
Resistance to solvents	Marking Unsmearred	MIL-STD-202 Method 215 Add Aqueous wash chemical - OKEM Clean or equivalent. Do not use banned solvents.
Flammability	No ignition of the tissue paper or scorching or the pinewood board	UL-94 V-0 or V-1 are acceptable. Electrical test not required.
Sulfur Test	ΔR±1%	ASTM-B-809-95 Modified 105±2 °C no power rating for 750 hrs.

RCWV(Rated continuous working voltage)= $\sqrt{P \cdot R}$ or Max. Operating voltage whichever is lower

- Storage Temperature: 15~28°C; Humidity < 80%RH
- Shelf Life: 2 years from production date.

■ Soldering Condition(IPC/JEDEC J-STD-020)

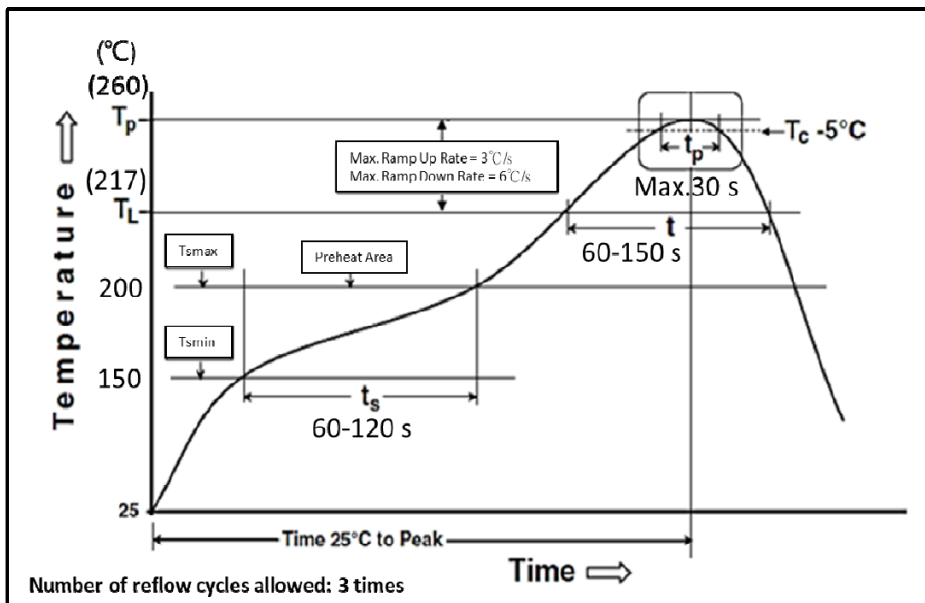

Marking

1206 4digit marking

Example

Resistance	100Ω	2.2KΩ	10KΩ	49.9KΩ	100KΩ
marking	1000	2201	1002	4992	1003

Packaging

Packing Quantity & Reel Specifications

Unit :mm

Type	ØA	ØB	ØC	W	T	Paper Tape (EA)	Emboss Plastic Tape (EA)
ARP06	178.0±1.0	60.0±1.0	13.5±0.7	9.5±1.0	11.5±1.0	5,000	-

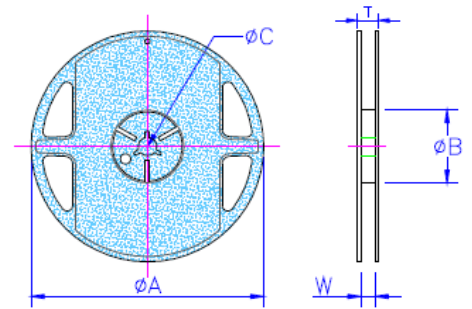

Paper Tape Specifications

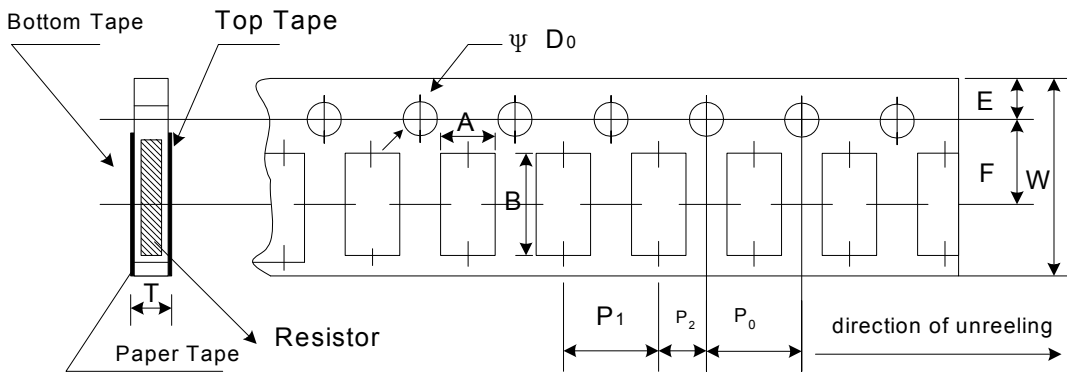

Unit: mm

Type	A	B	W	E	F	P ₀	P ₁	P ₂	ΦD ₀	T
ARP06	2.00±0.05	3.55±0.05	8.00±0.10	1.75±0.05	3.5±0.05	4.00±0.10	4.00±0.10	2.00±0.05	1.55±0.05	0.75±0.05

- Peel force of top cover tape
- The peel speed shall be about 300mm/min±5%
- The peel force of top cover tape shall be between 8gf to 60gf

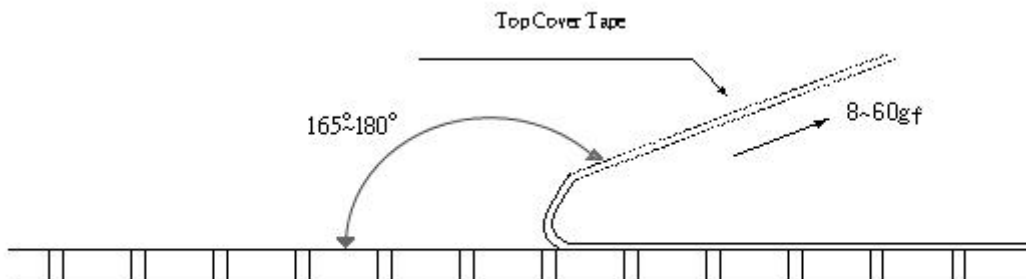

■ Recommend Land Pattern

Unit: mm

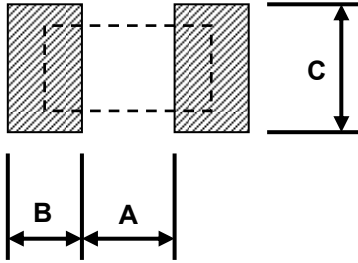

Type	A	B	C
1206	0.8	1.90	1.80

- Please design the land pattern considering heat dissipation to the board so that the terminal temperature will not exceed 155°C.